

by winsa

Revotech

REVOLUTION IN WINDOW TECHNOLOGY

FABRICATION MANUAL

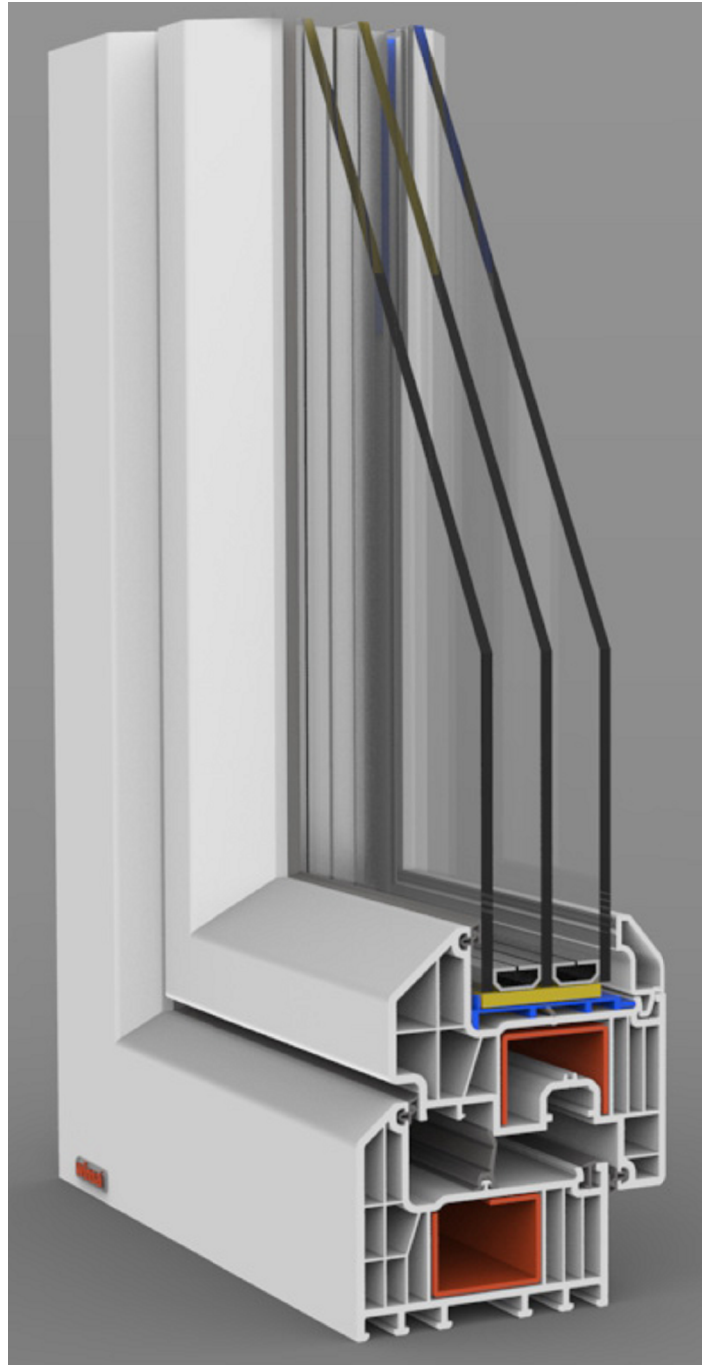

winsa[®]

PVC WINDOW , DOOR , ROLLER SHUTTER SYSTEMS

AUGUST 2014

	<u>page number</u>
System Overview	1.1 – 1.5
Cutting Sizes	2.1 – 2.2
Preparations of Profiles	3.1 – 3.10
Accessories	4.1 – 4.8
Welding & Corner Cleaning	5.1 – 5.9
Preparation of Transom	6.1 – 6.2
Glazing Wedges	7.1

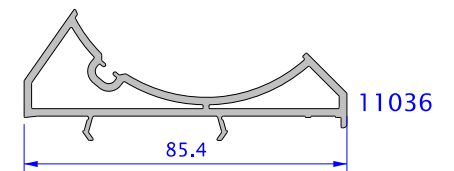
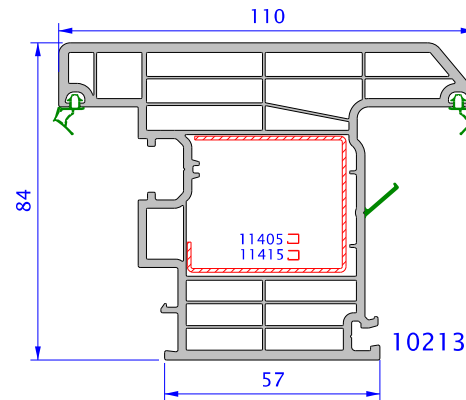
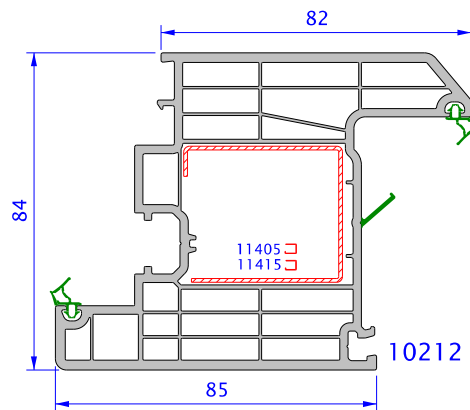
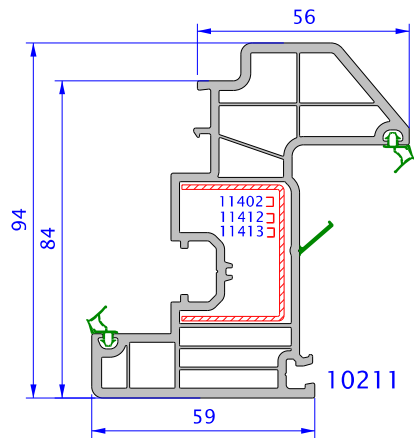
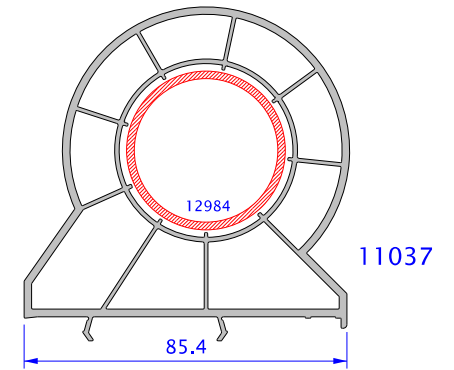
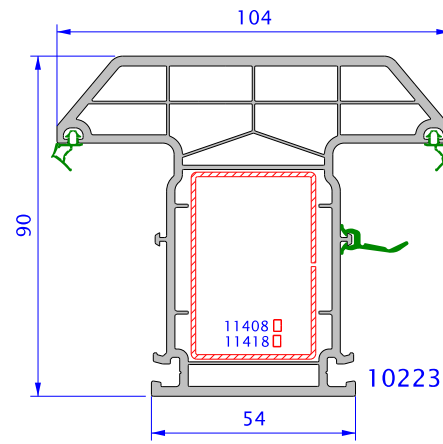
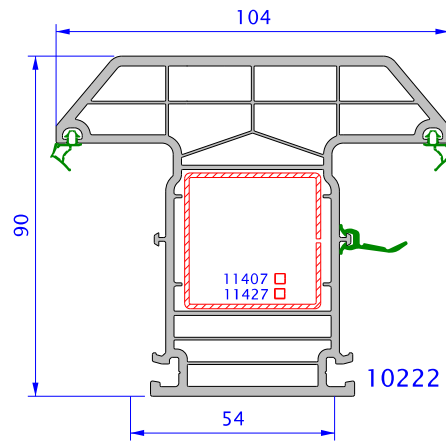
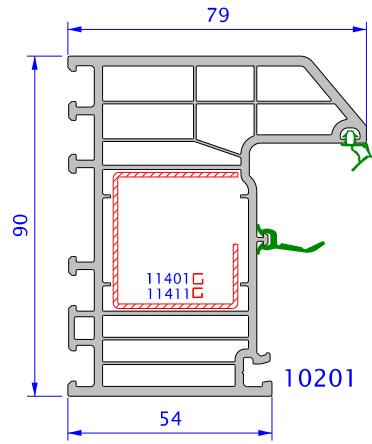
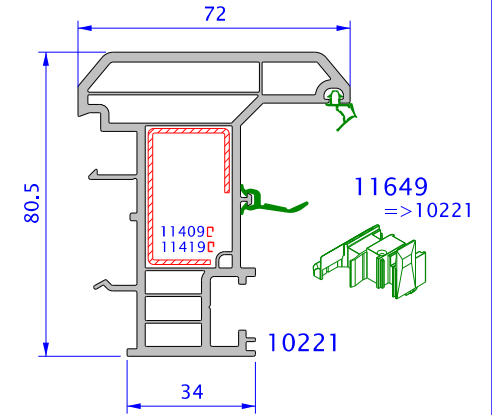
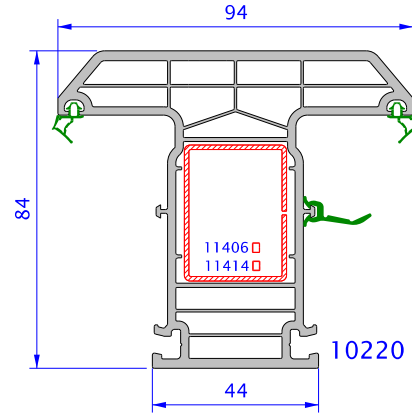
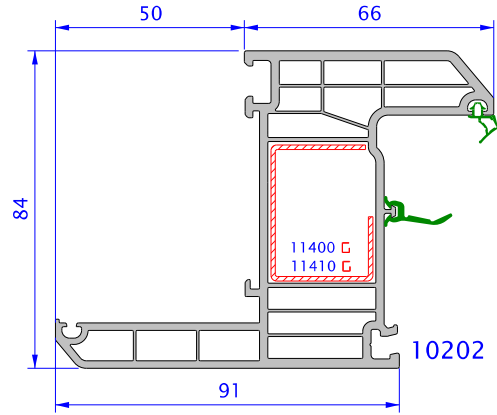
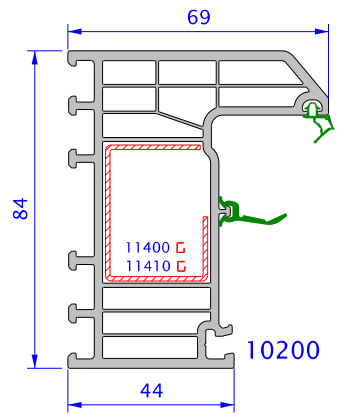

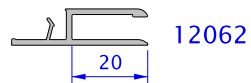
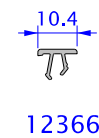
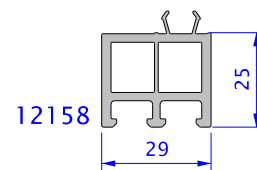
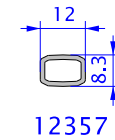
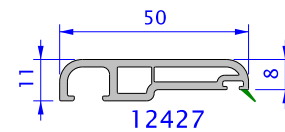
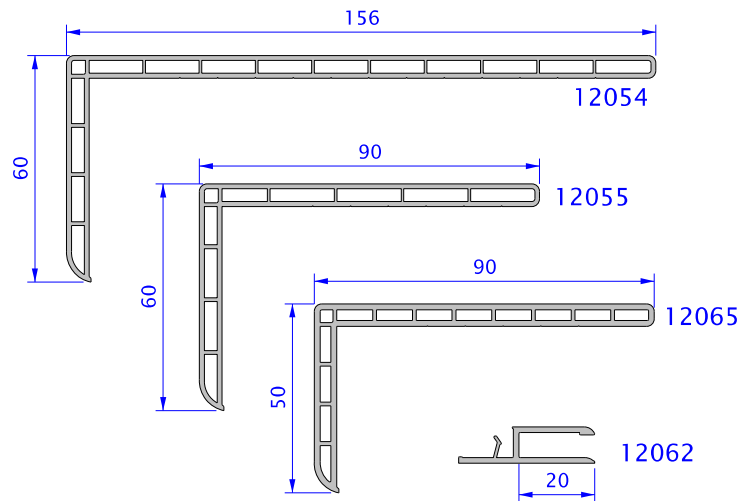
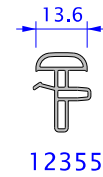
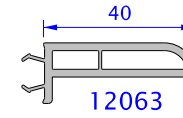
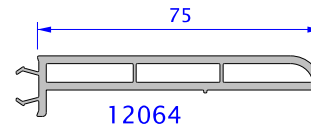
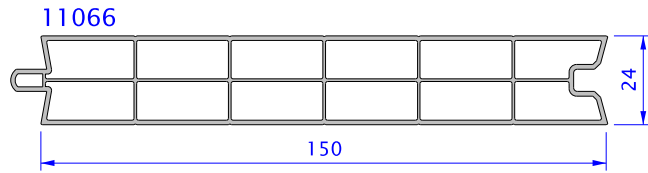
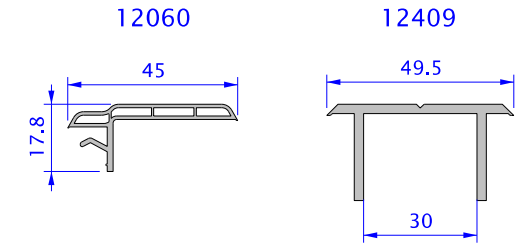
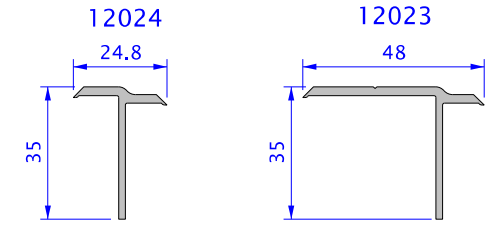
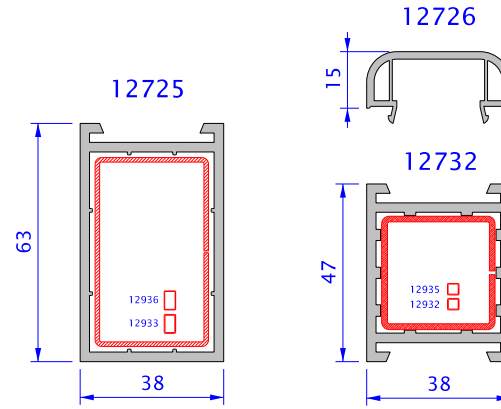
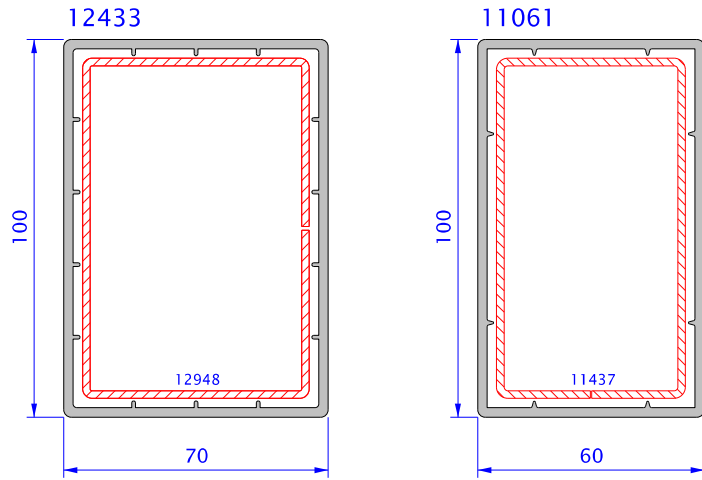

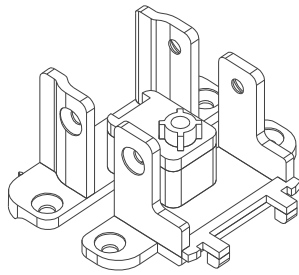

10547
=> 10220

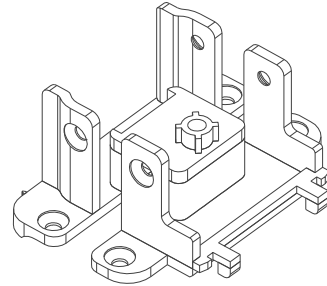

10548
=> 10222/10223

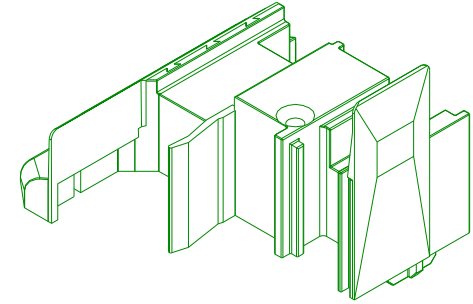

11649
=> 10221

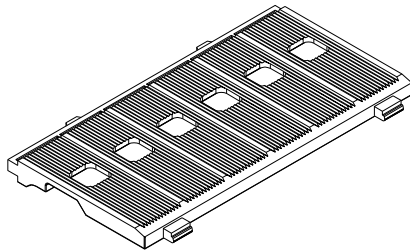

11651

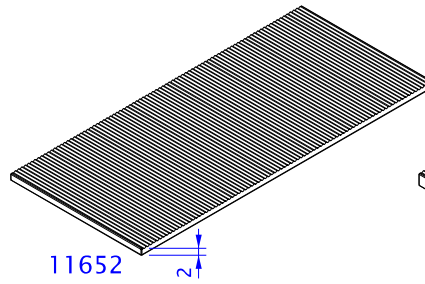

11652
2

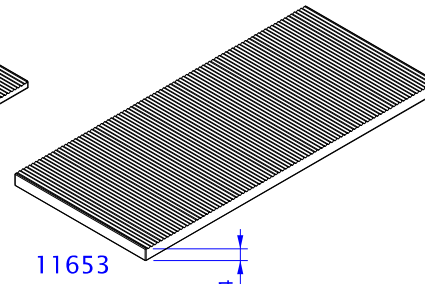

11653
4



10576

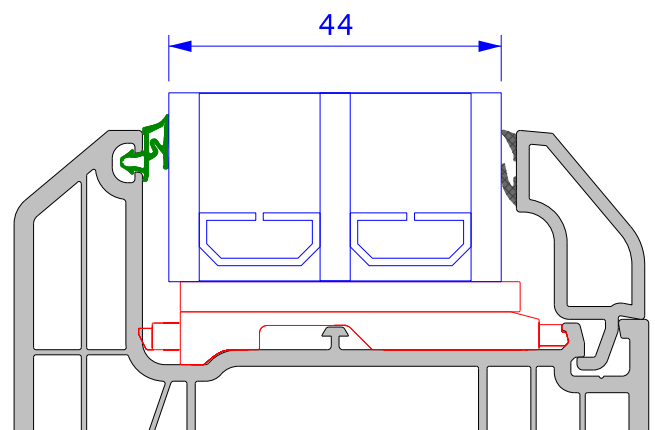
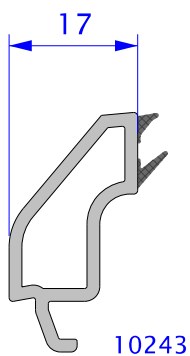
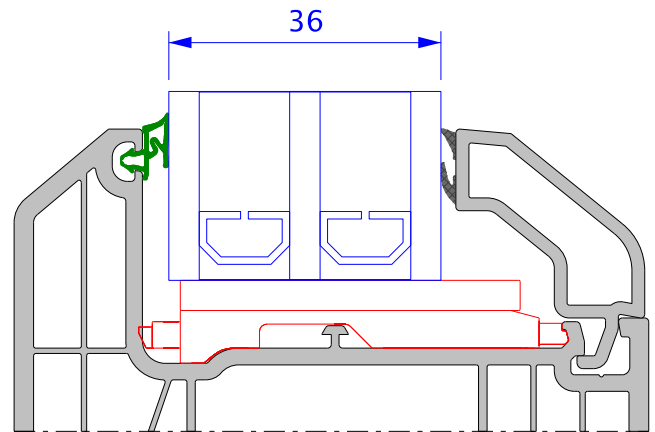
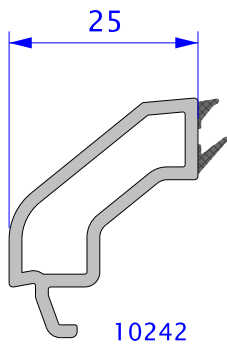
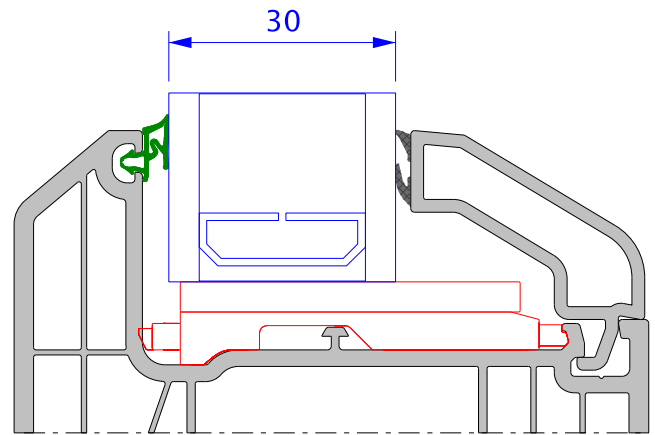
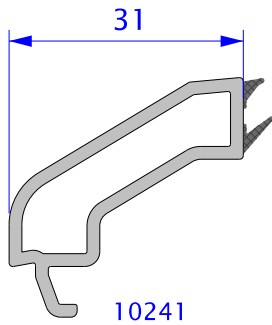
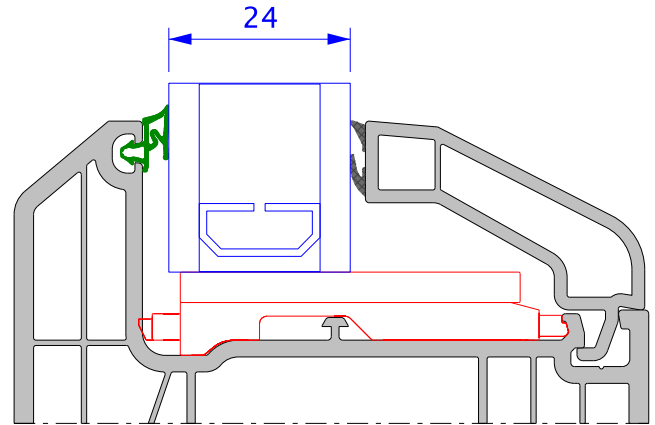
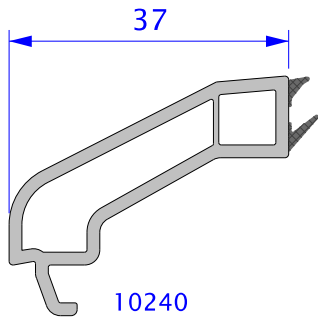

10200		11400	11410
		25x36x27x17x1.2	25x36x27x17x1.5
	Ix (cm⁴)	2.3840	2.9143

10201		11401	11411
		17x33x36x1.2	17x33x36x1.5
	Ix (cm⁴)	2.9081	3.5581

10220		11406	11414
		27x36x1.2	27x36x2
	Ix (cm⁴)	2.6670	4.0591

10222		11407	11427
		36x36x1.2	36x36x2
	Ix (cm⁴)	3.3212	5.2037

10221		11409	11419
		17x21.5x36x16.5x1.2	17x21.5x36x16.5x2
	Ix (cm⁴)	1.8413	2.8736

10223		11408	11418
		33x49.5x1.2	33x49.5x2
	Ix (cm⁴)	6.6064	10.4857

10211		11402	11412
		27x36x1.2	27x36x1.5
		2.3154	2.8342
		11413	
		27x36x2	
	Ix (cm⁴)	3.6440	

10212		11405	11415
10213			
		8x42x36x40x1.2	8x42x36x40x2
	Ix (cm⁴)	3.4544	5.4368

* Kanat hesaplarına kaynak payı dahildir. Kanat binme payı 9 mm'dir

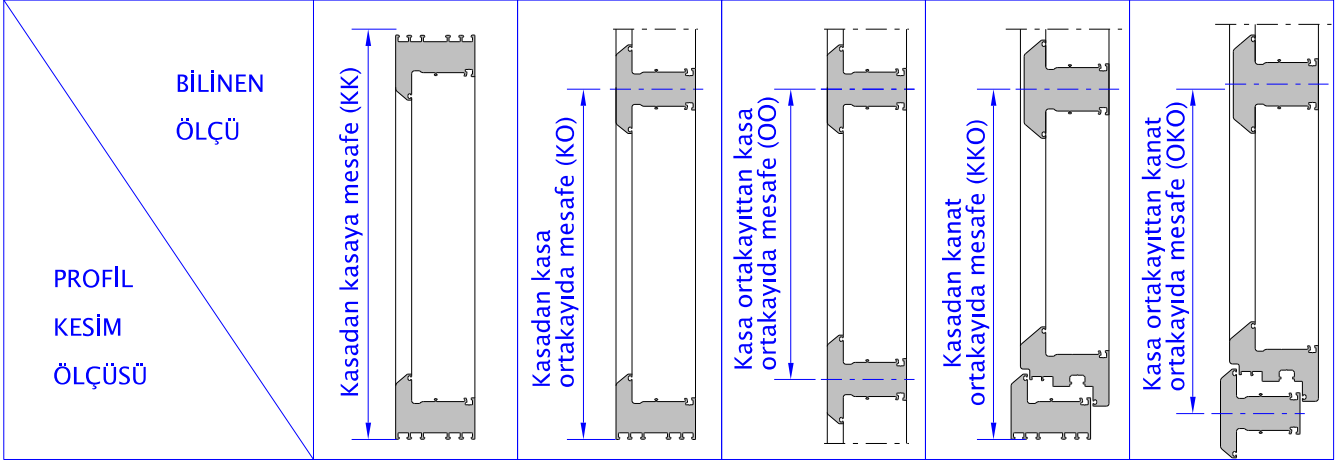

* Bütün kasalara +6 ilave edilir.

10200-KASA 84	KANAT HESABI	10211	-64	-42	-20	-	-
ORTAKAYIT HESABI	10200-Kasa Fix	-88	-66	-44	-	-	
	10211	-188	-166	-144	10122	-121	-99
10212/10213	-240	-218	-196	10122	-147	-125	
CAM HESABI	10200-Kasa Fix	-108	-86	-64	-	-	
	10211	-208	-186	-164	10122	-141	-119
10212/10213	-260	-238	-216	10122	-167	-145	

10201-KASA 90	KANAT HESABI	10211	-84	-52	-20	-	-
ORTAKAYIT HESABI	10201-Kasa Fix	-108	-76	-44	-	-	
	10211	-208	-176	-144	10122	-131	-99
10212/10213	-260	-228	-196	10122	-157	-125	
CAM HESABI	10201-Kasa Fix	-128	-96	-64	-	-	
	10211	-228	-196	-164	10122	-151	-119
10212/10213	-280	-248	-216	10122	-177	-145	

10202-PERVAZ KASA	KANAT HESABI	10211	-158	-89	-20	-	-
ORTAKAYIT HESABI	10202-Kasa Fix	-182	-113	-44	-	-	
	10211	-282	-213	-144	10122	-168	-99
10212/10213	-334	-265	-196	10122	-194	-125	
CAM HESABI	10202-Kasa Fix	-202	-133	-64	-	-	
	10211	-102	-233	-164	10122	-188	-119
10212/10213	-354	-285	-216	10122	-214	-145	

Not : Kanat hesaplarına kaynak payı dahildir.

Kanat Adaptör Kesim Ölçüsü : Bu ölçü kanadın kaynak paylı ölçüsünden 98 mm düşülecektir.

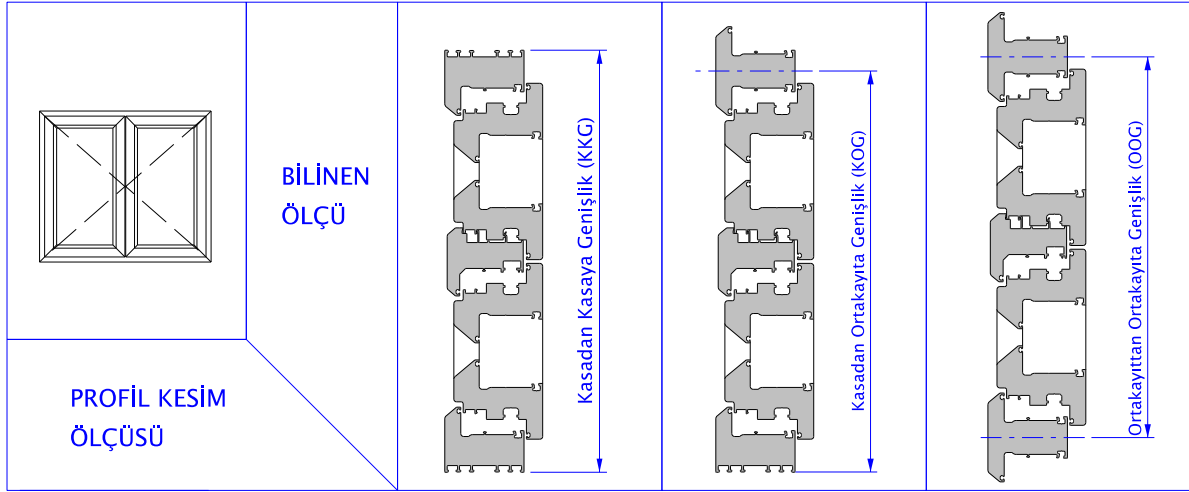

		KASA TİP	KANAT TİP	YATAY	DİKEY	YATAY	DİKEY	YATAY	DİKEY
KANAT HESABI	10200-Kasa 84	Tüm Tipler	$\frac{KKG-62}{2}$	-64	$\frac{KKG-40}{2}$	-42	$\frac{KKG-18}{2}$	-20	
	10201-Kasa 90	Tüm Tipler	$\frac{KKG-82}{2}$	-84	$\frac{KKG-50}{2}$	-52	$\frac{KKG-18}{2}$	-20	
	10202-Pervaz Kasa	Tüm Tipler	$\frac{KKG-156}{2}$	-158	$\frac{KKG-87}{2}$	-89	$\frac{KKG-18}{2}$	-20	
ORTAKAYIT HESABI	10200-Kasa 84	10211	$\frac{KKG-310}{2}$	-188	$\frac{KKG-288}{2}$	-166	$\frac{KKG-266}{2}$	-144	
		10212 / 10213	$\frac{KKG-414}{2}$	-240	$\frac{KKG-392}{2}$	-218	$\frac{KKG-370}{2}$	-196	
	10201-Kasa 90	10211	$\frac{KKG-330}{2}$	-208	$\frac{KKG-298}{2}$	-176	$\frac{KKG-266}{2}$	-144	
		10212 / 10213	$\frac{KKG-434}{2}$	-260	$\frac{KKG-402}{2}$	-228	$\frac{KKG-370}{2}$	-196	
	10202-Pervaz Kasa	10211	$\frac{KKG-404}{2}$	-282	$\frac{KKG-335}{2}$	-213	$\frac{KKG-266}{2}$	-144	
		10212 / 10213	$\frac{KKG-508}{2}$	-334	$\frac{KKG-439}{2}$	-265	$\frac{KKG-370}{2}$	-196	
CAM HESABI	10200-Kasa 84	10211	$\frac{KKG-350}{2}$	-208	$\frac{KKG-328}{2}$	-186	$\frac{KKG-306}{2}$	-164	
		10212 / 10213	$\frac{KKG-454}{2}$	-260	$\frac{KKG-432}{2}$	-238	$\frac{KKG-410}{2}$	-216	
	10201-Kasa 90	10211	$\frac{KKG-370}{2}$	-228	$\frac{KKG-438}{2}$	-196	$\frac{KKG-306}{2}$	-164	
		10212 / 10213	$\frac{KKG-474}{2}$	-280	$\frac{KKG-442}{2}$	-248	$\frac{KKG-410}{2}$	-216	
	10202-Pervaz Kasa	10211	$\frac{KKG-444}{2}$	-302	$\frac{KKG-375}{2}$	-233	$\frac{KKG-306}{2}$	-164	
		10212 / 10213	$\frac{KKG-548}{2}$	-354	$\frac{KKG-479}{2}$	-285	$\frac{KKG-410}{2}$	-216	

Not :

* Kasadan, kanat ortakayıtta ve kasa ortakayıtтан olan hesaplamalar Sayfa 2.1 kullanılarak yapılabilir.

* İki kanadın (ve camlarının) eşit olduğu varsayılmıştır. Farklı genişlikte olması isteniyorsa, önce eşit hesaplanır ve fark bir kanattan çıkartılıp, diğer kanada eklenir

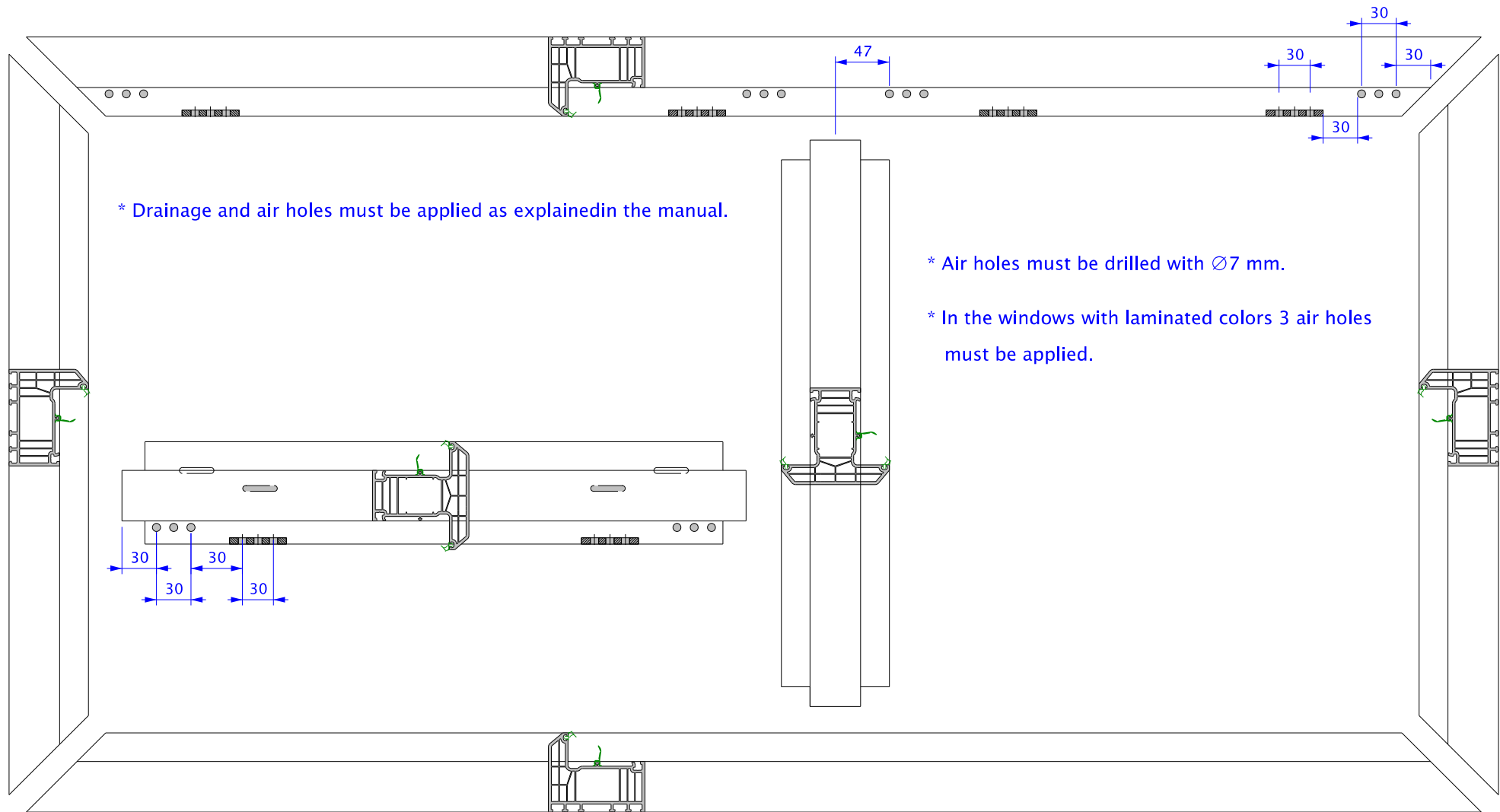

* Drainage and air holes must be applied as explained in the manual.

* Air holes must be drilled with $\varnothing 7$ mm.

* In the windows with laminated colors 3 air holes must be applied.

- * The width of frame or frame to transom axe length,
 - * If it is lower than 400 mm the drainage is applied as 2 holes from inside, 1 hole from outside.
 - * If this length is higher than 900 mm, third hole from inside and outside is drilled.
- * In the case of french opening applications, the false mullion profile is accepted as transom.

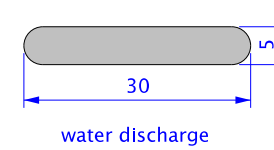
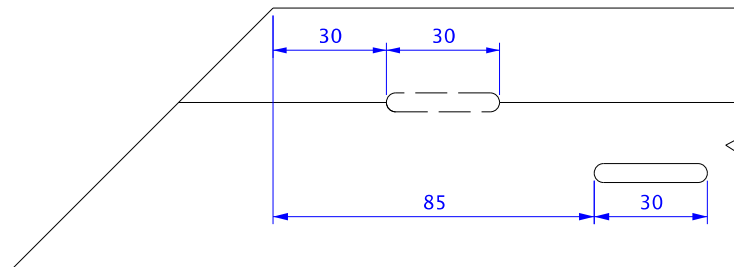
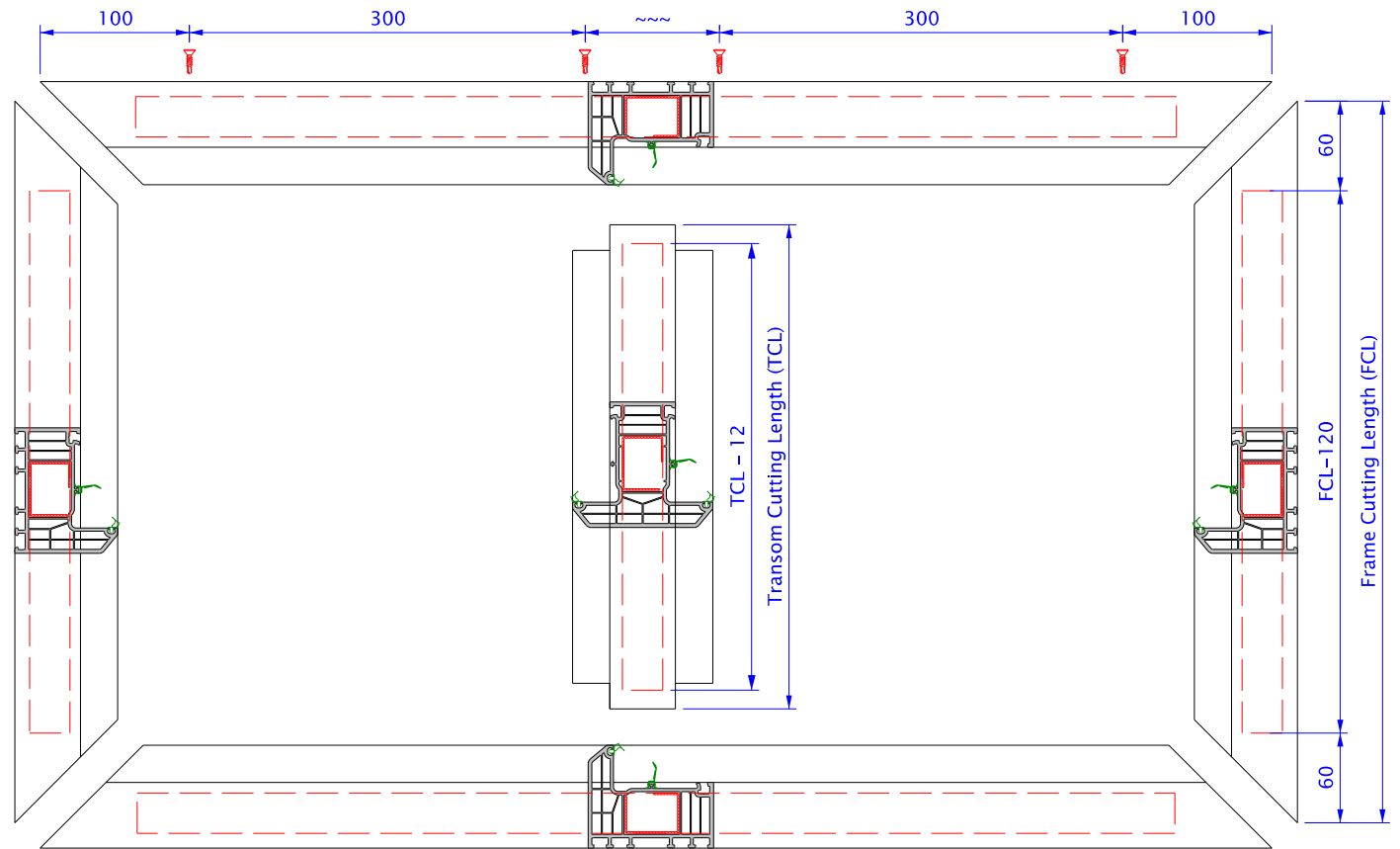
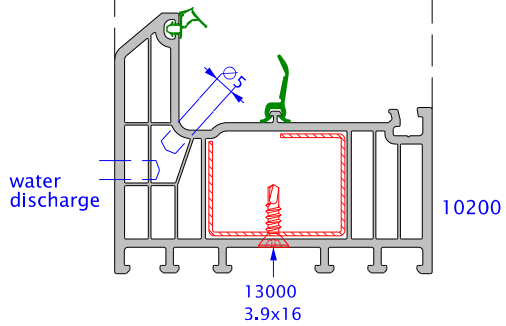
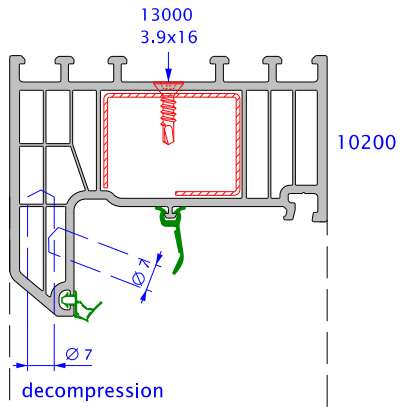

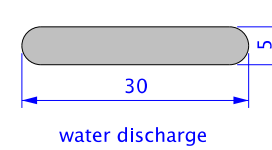
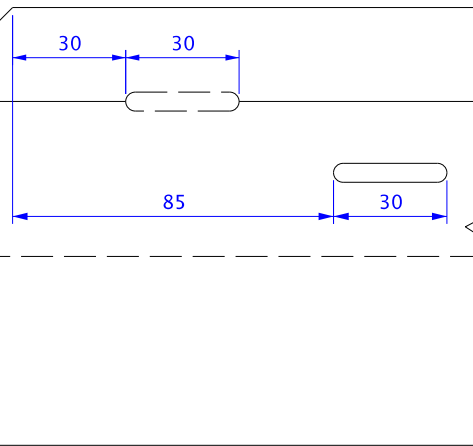
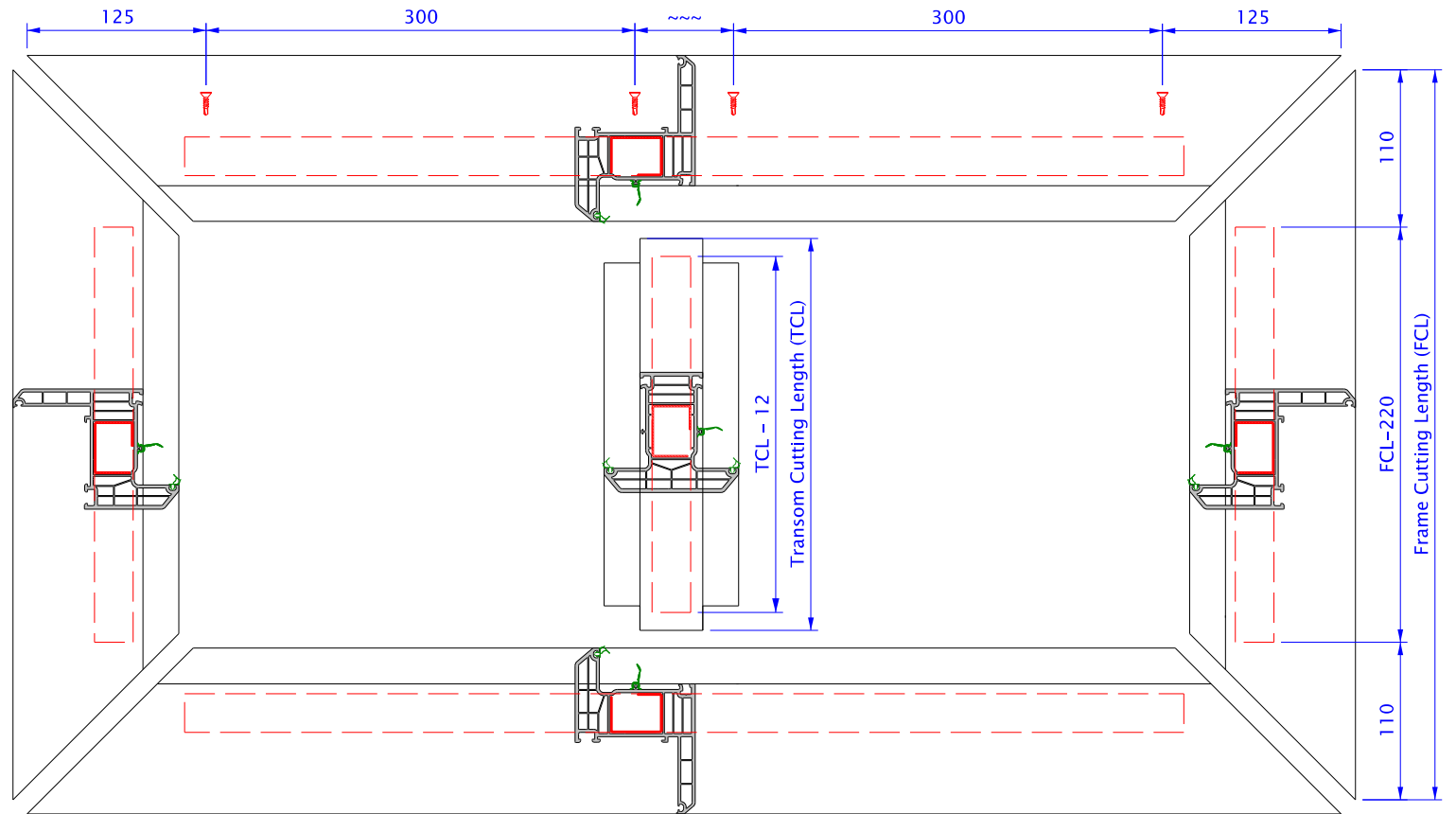
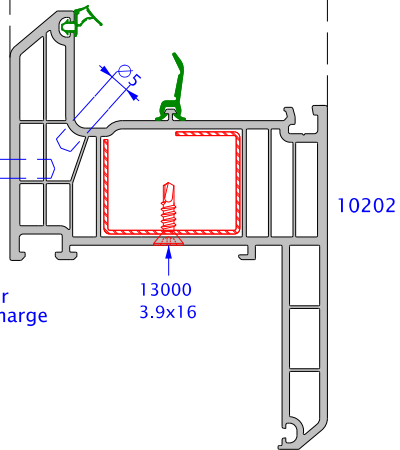
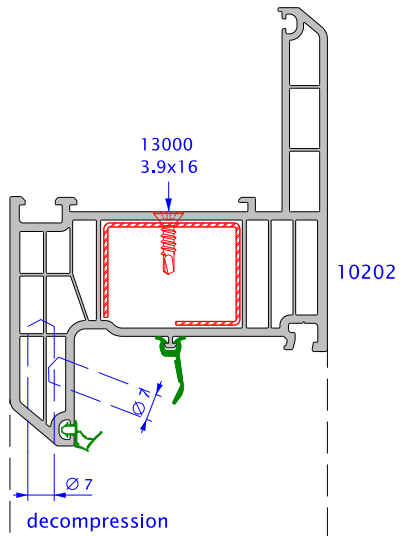

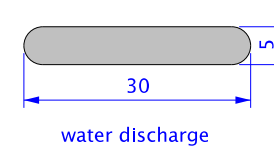
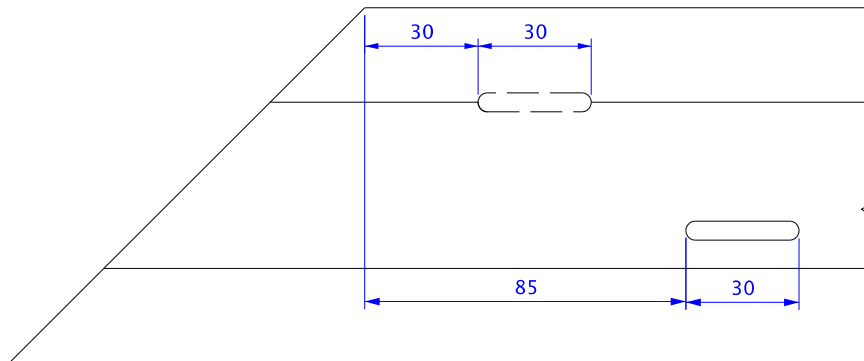
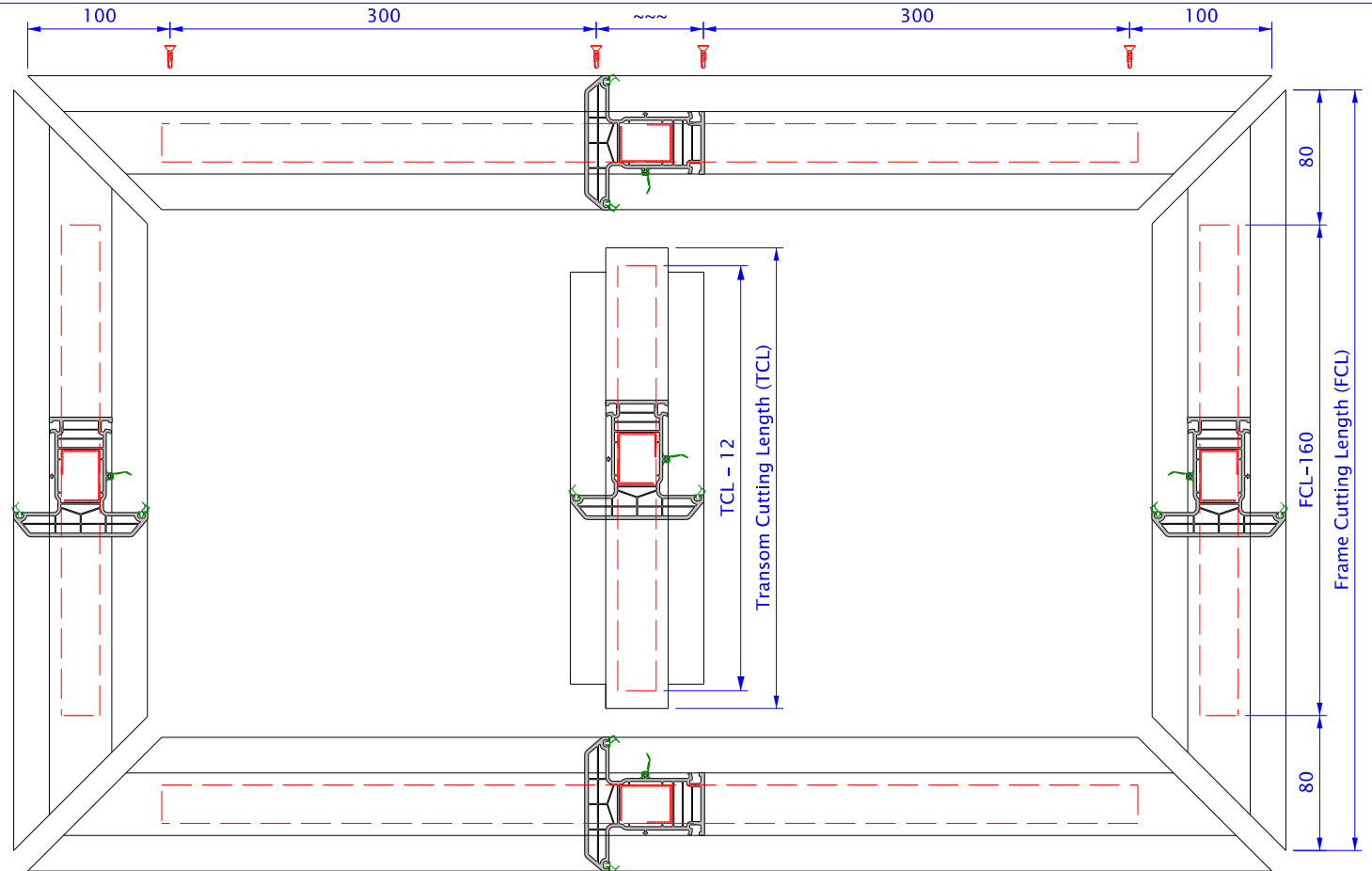
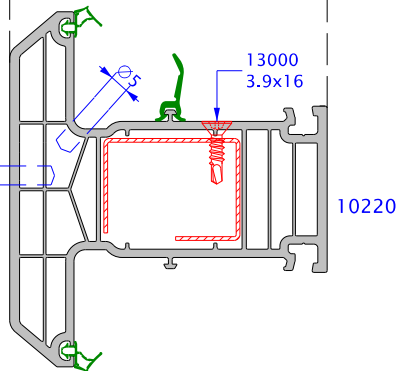
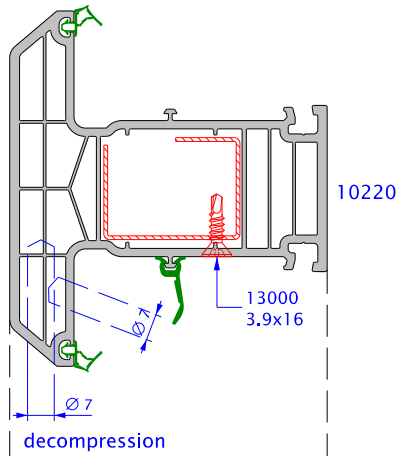

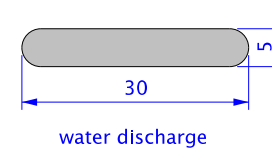
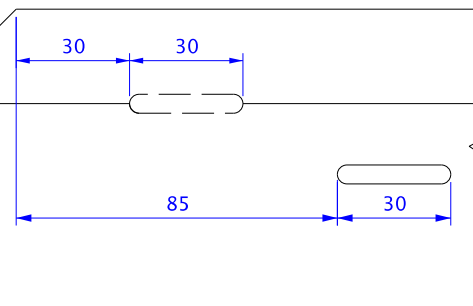
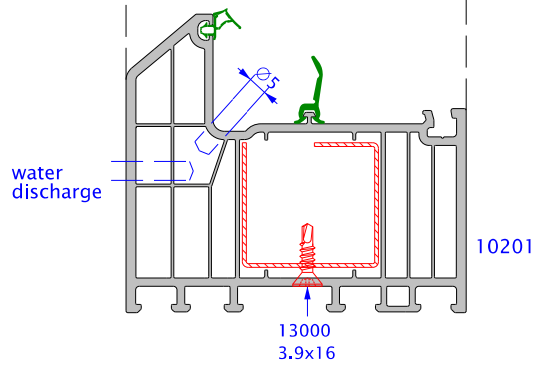
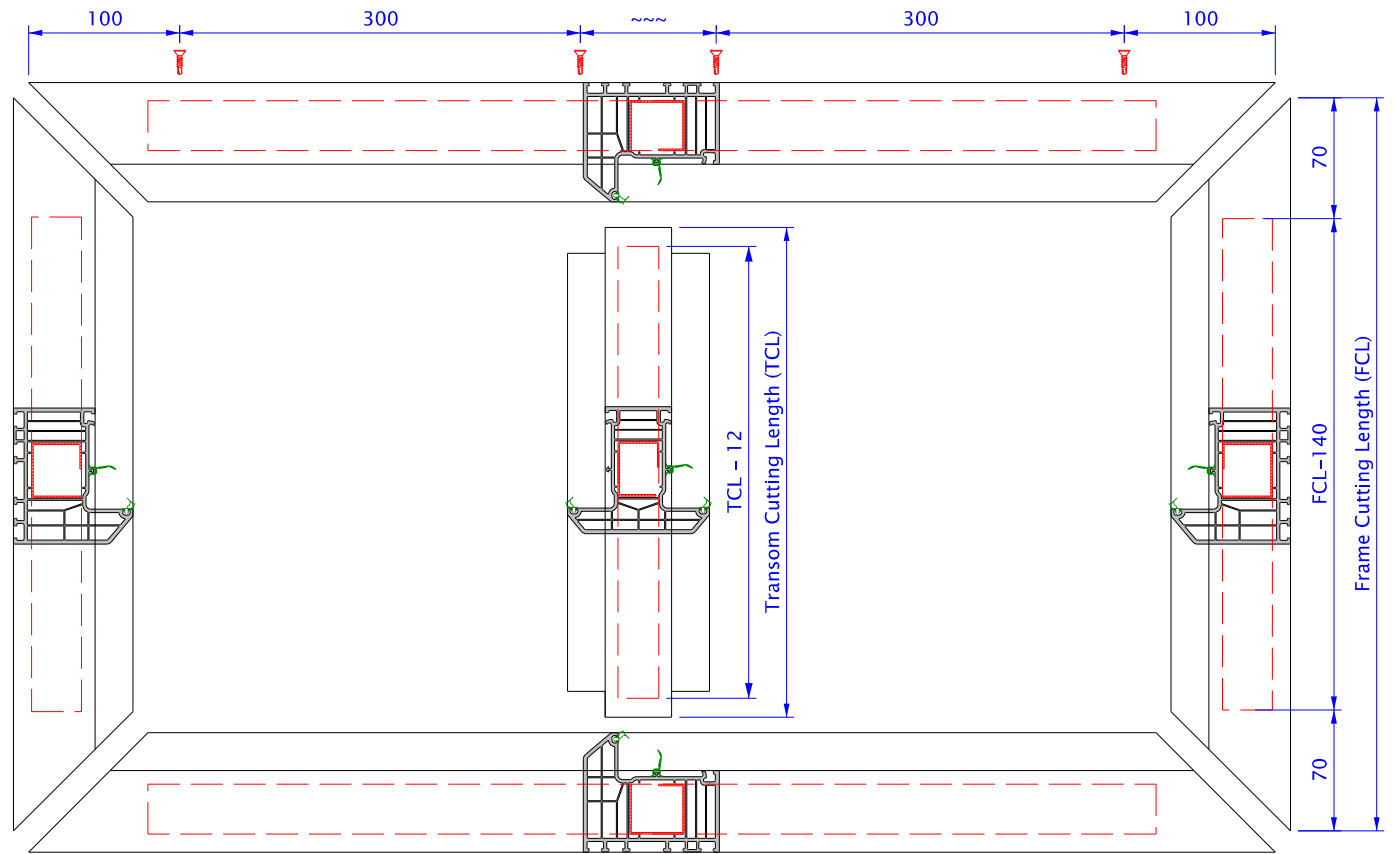
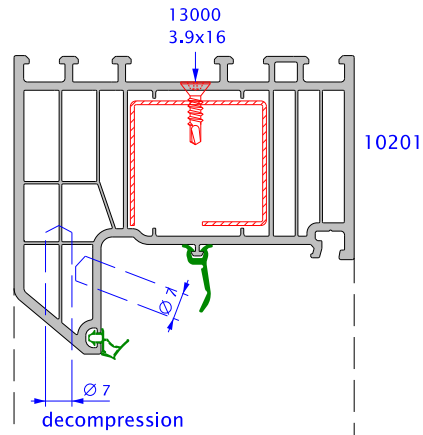

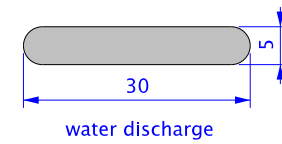
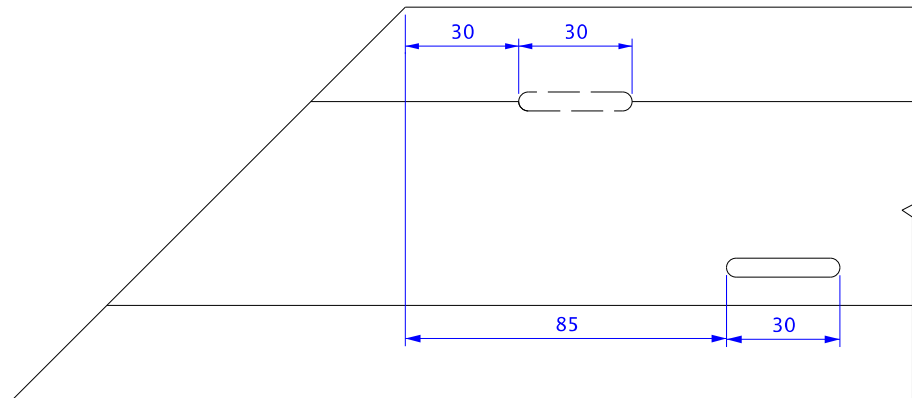
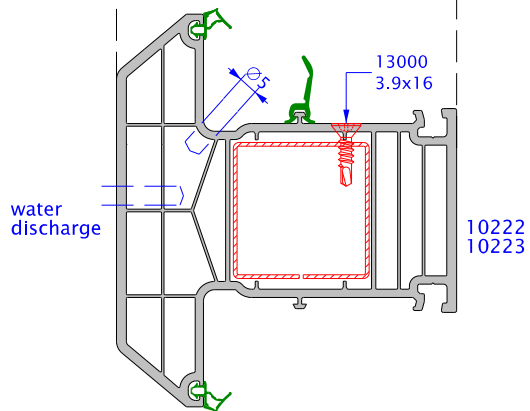
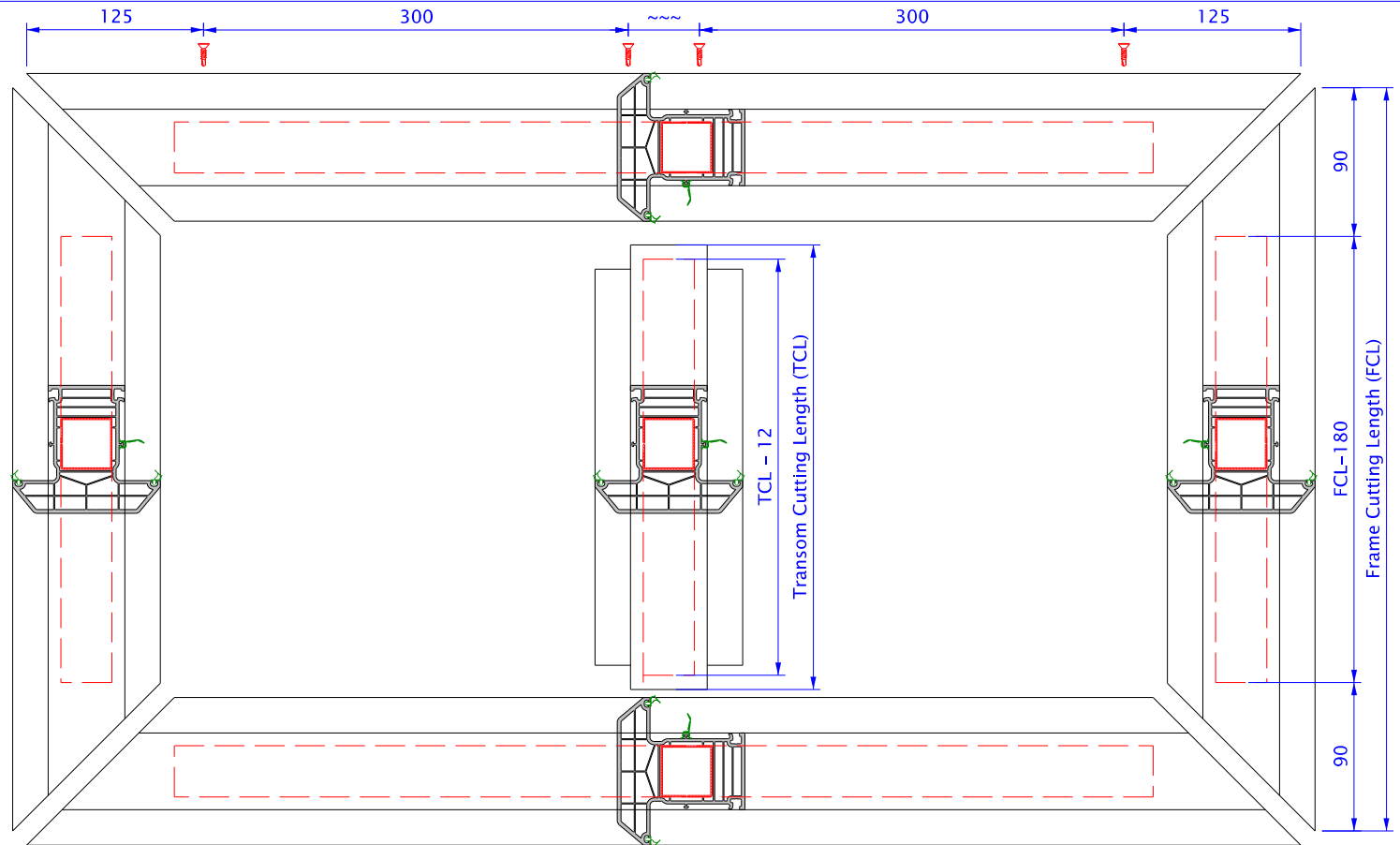
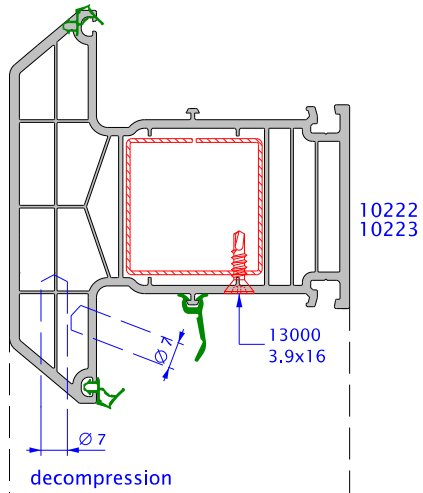

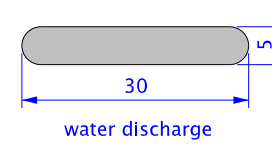
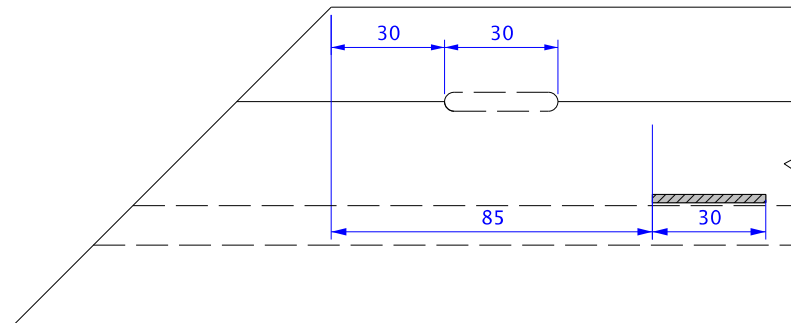
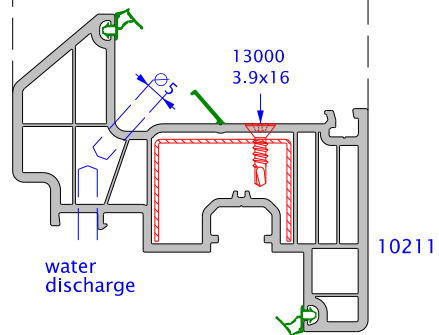
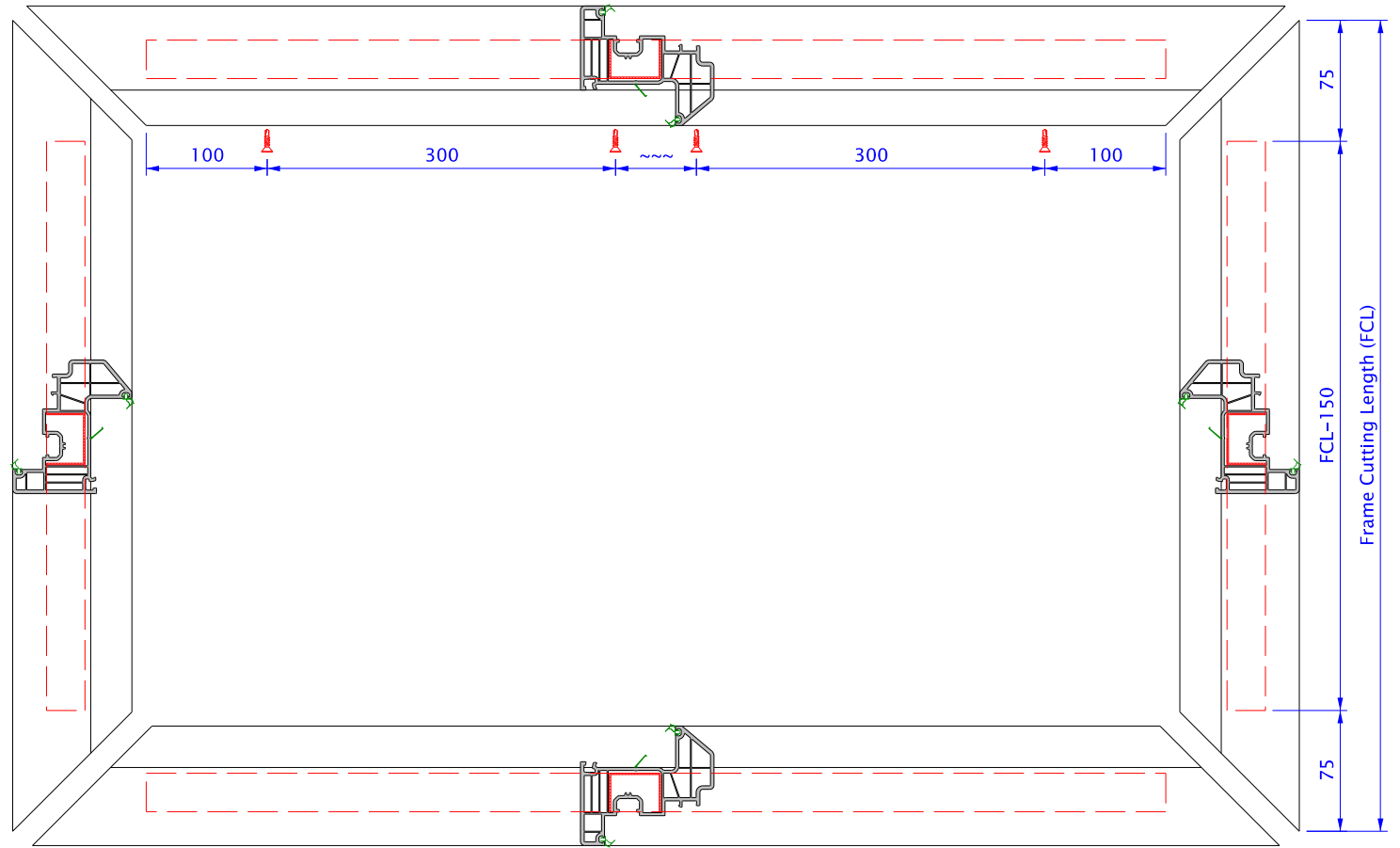
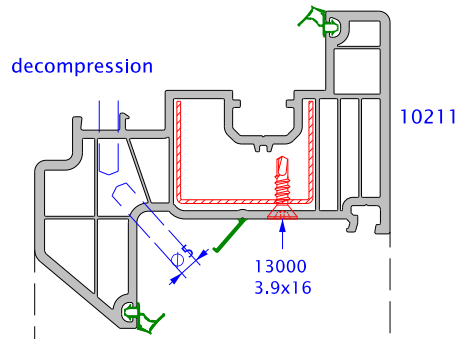

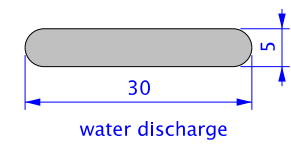
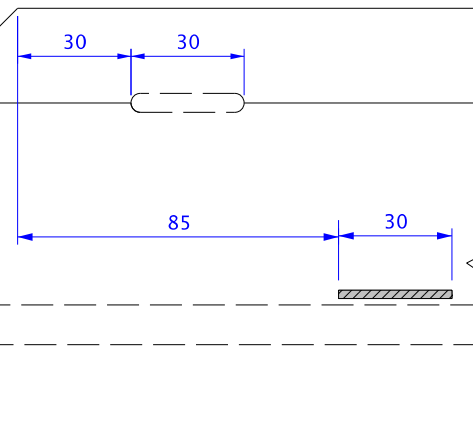
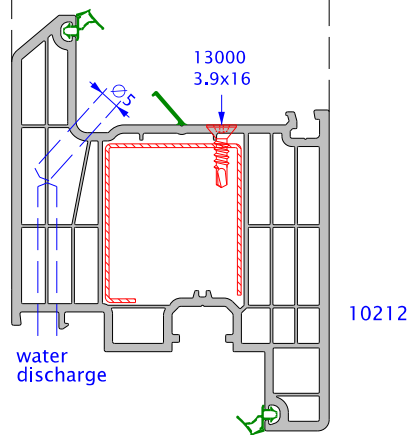
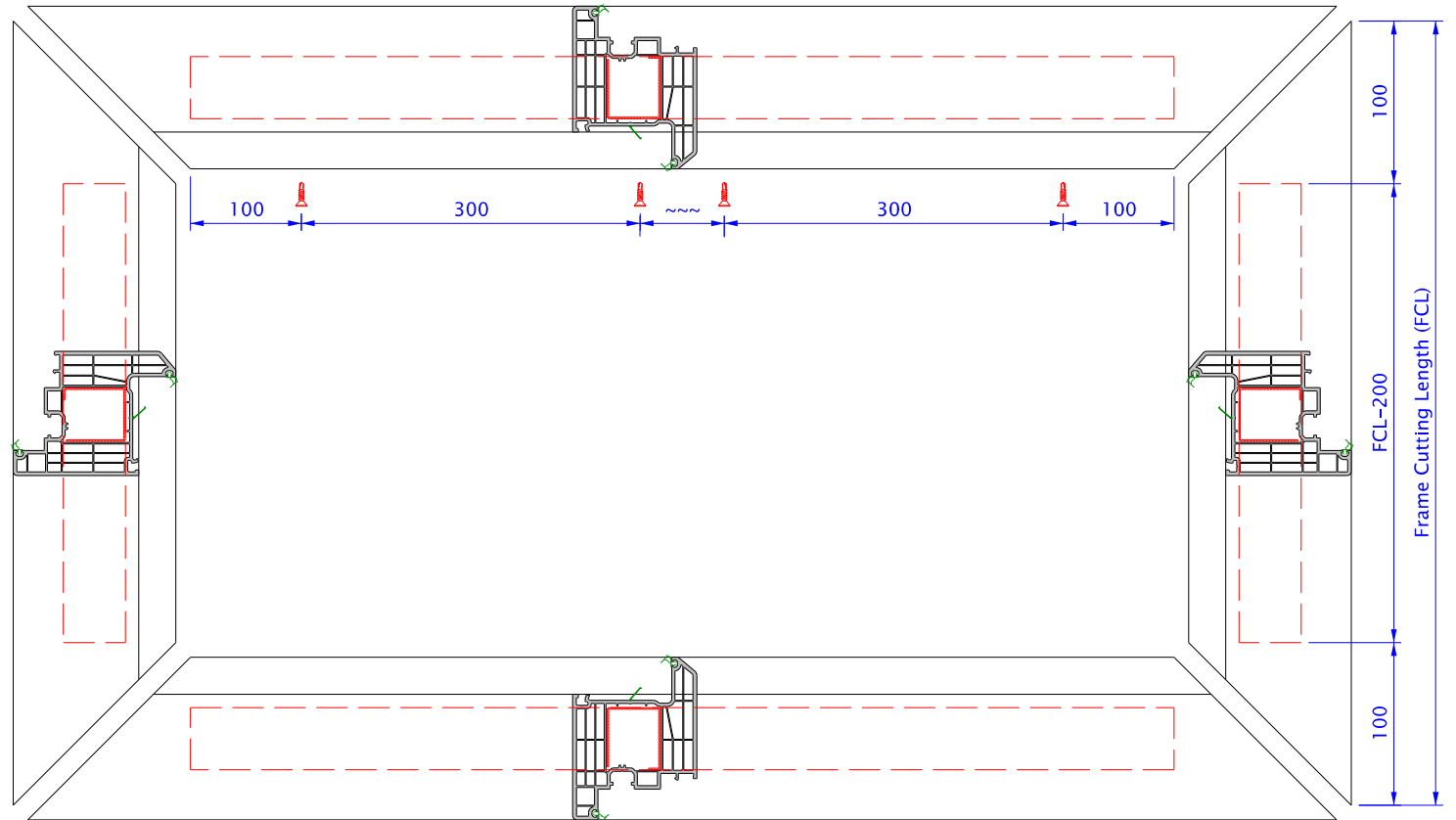
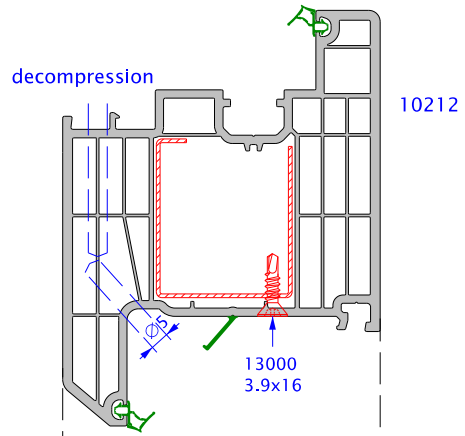

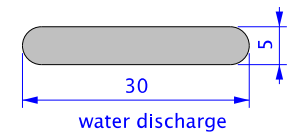
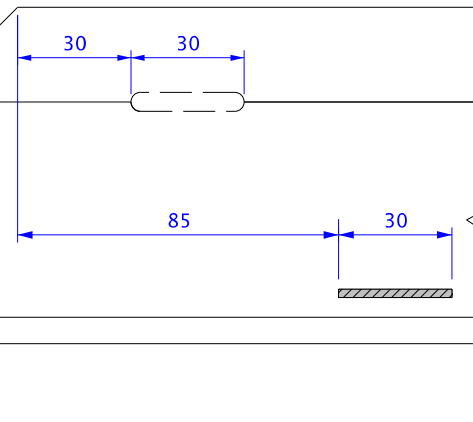
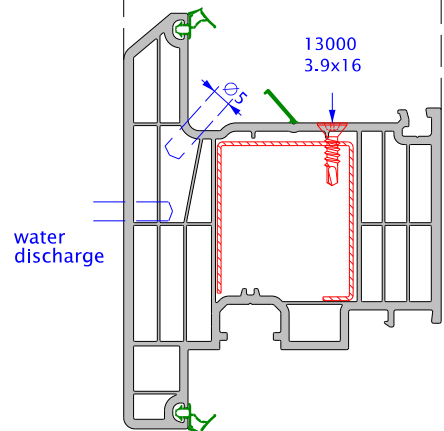
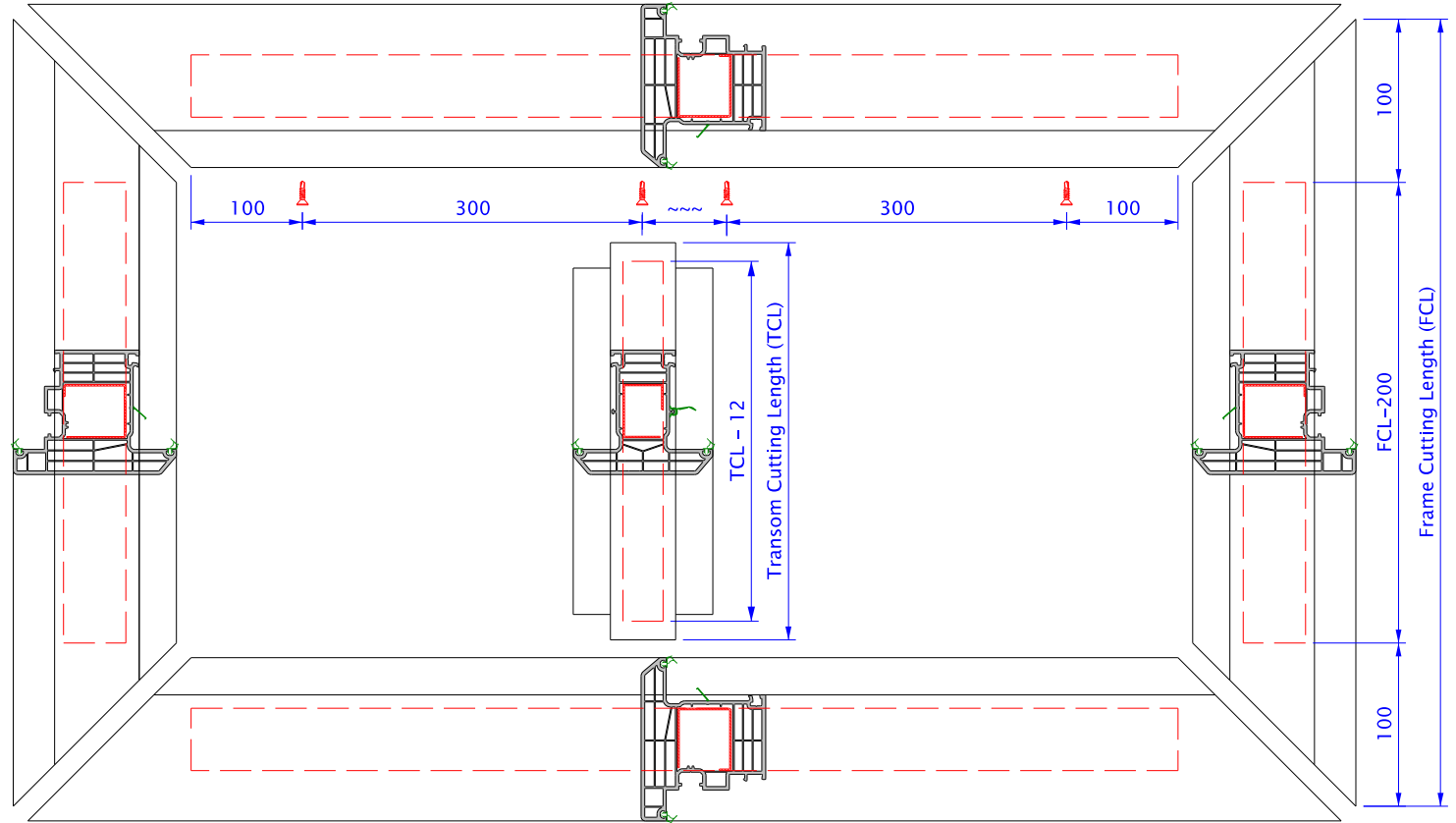
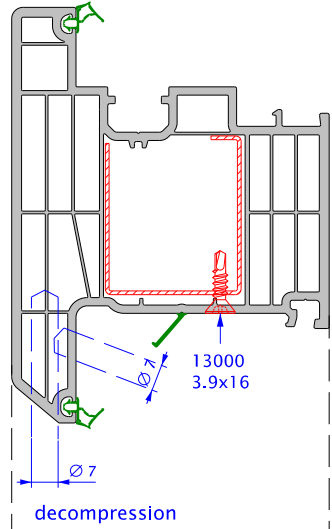

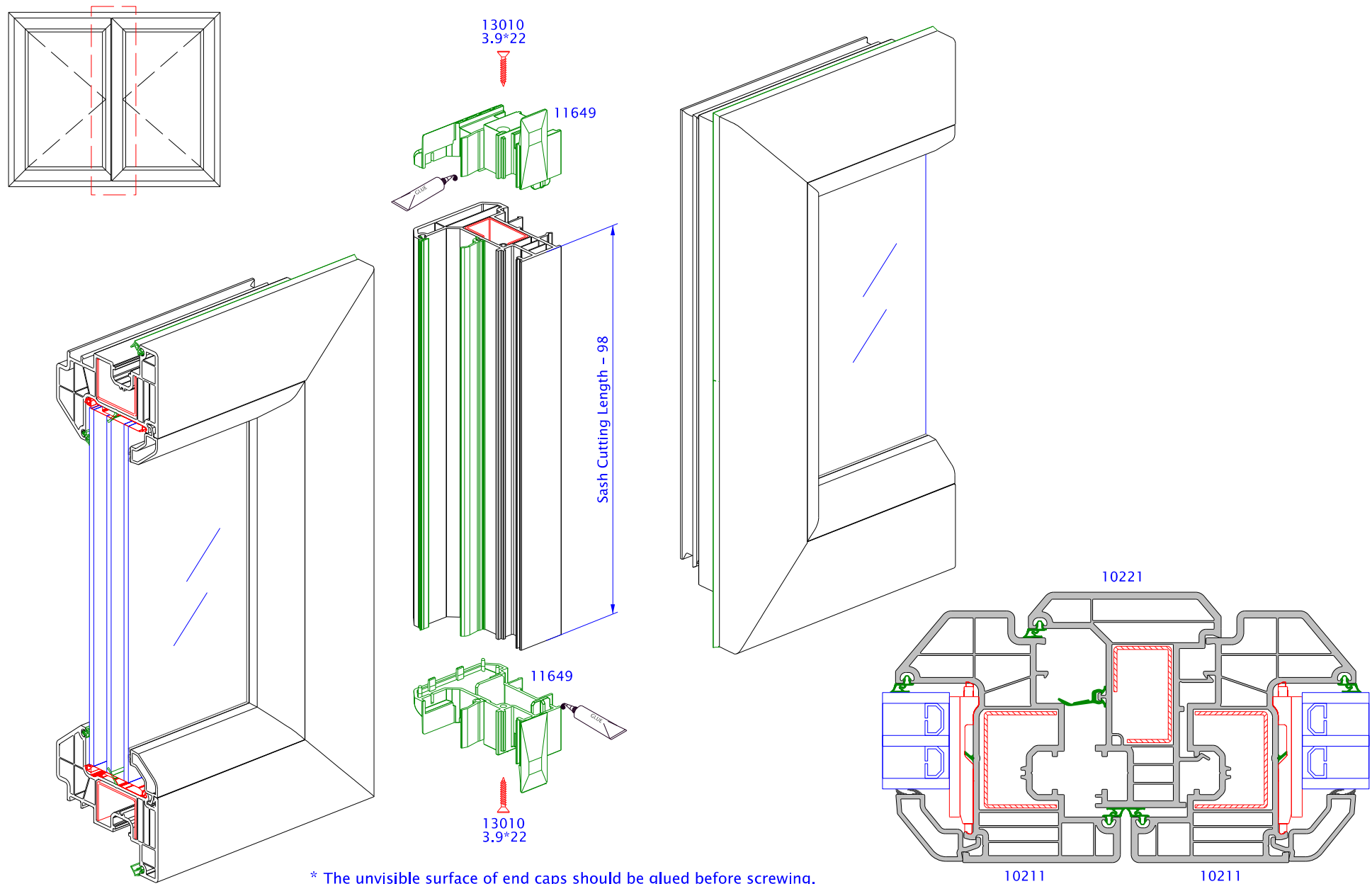

* The invisible surface of end caps should be glued before screwing.

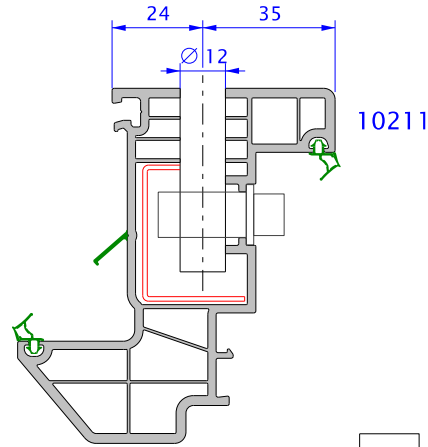

Turn Opening Espagnolettes

Product Number	Sash Dimension	Pin Number
10874	200 – 370	1
10875	370 – 600	2
10876	600 – 800	2
10877	800 – 1000	2
10878	900 – 1110	3
10879	1000 – 1200	3
10880	1200 – 1400	3
10881	1400 – 1600	4
10882	1600 – 1800	4
10883	1800 – 2000	4

10816
10825

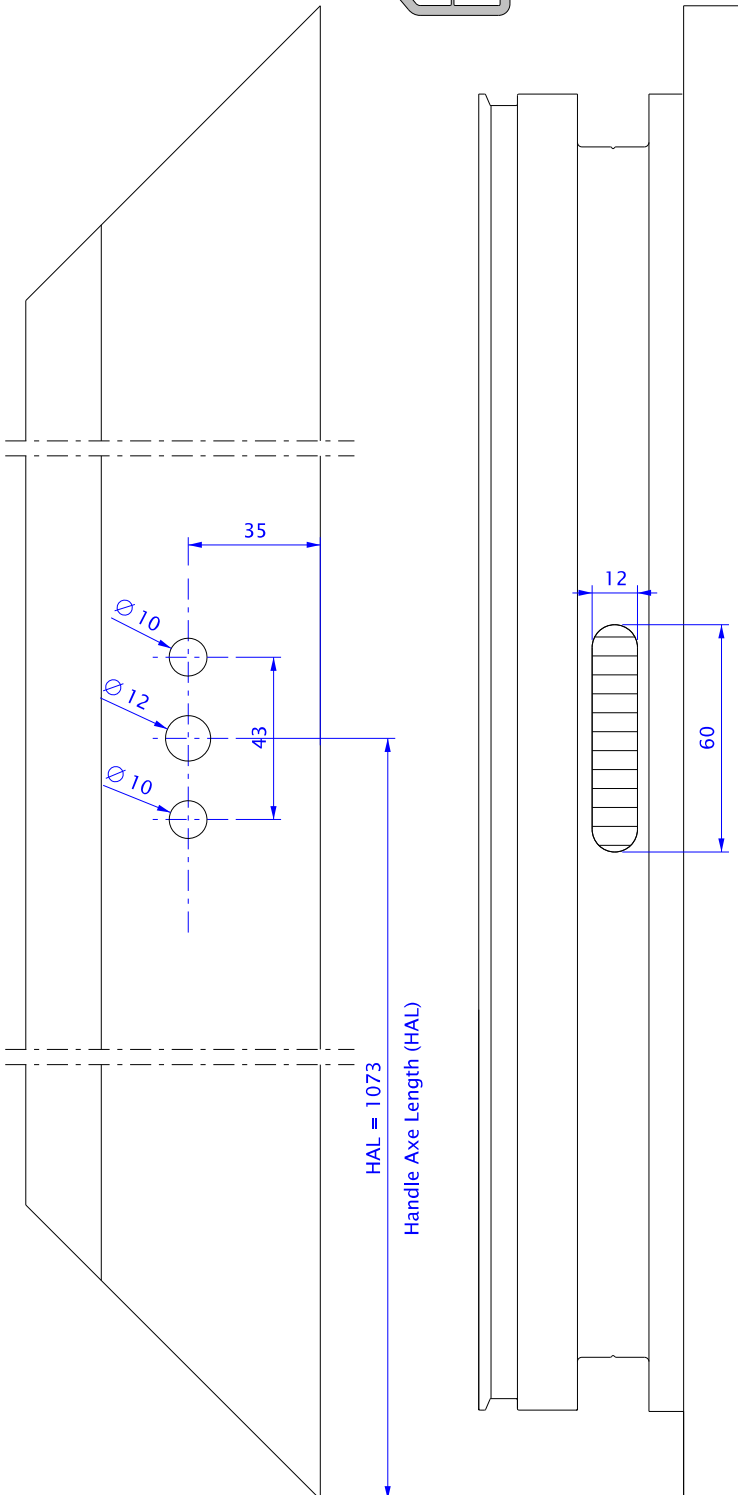

11574
11592
11596

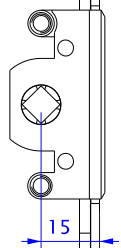
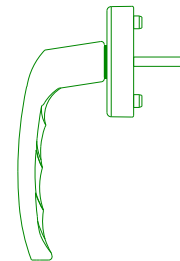

Turn Opening Eco.Espagnolettes

Product Number	Sash Dimension	Pin Number
10940	175 – 360	1
10941	360 – 600	2
10942	600 – 800	2
10943	800 – 1000	2
10944	1000 – 1200	3
10945	1200 – 1400	3
10946	1400 – 1600	4
10947	1600 – 1800	4
10948	1800 – 2000	4
10949	2000 – 2200	4

10816
10825

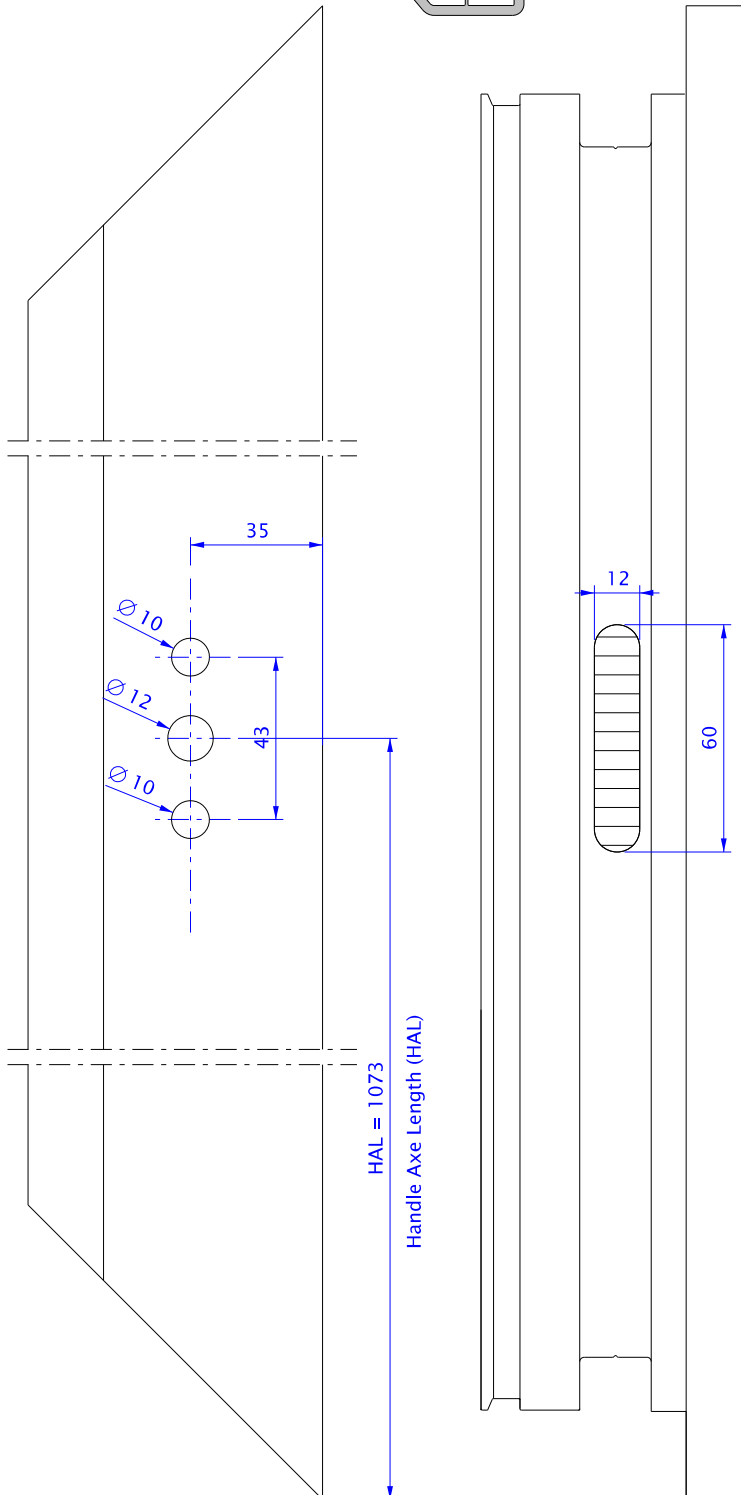
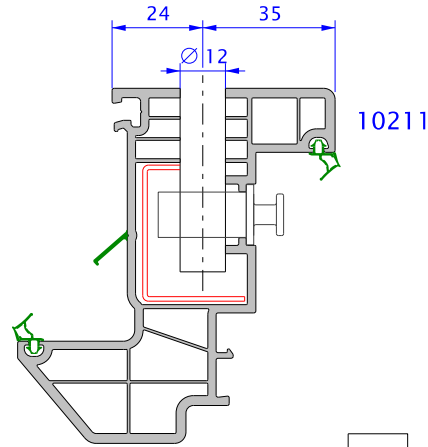

11574
11592
11596

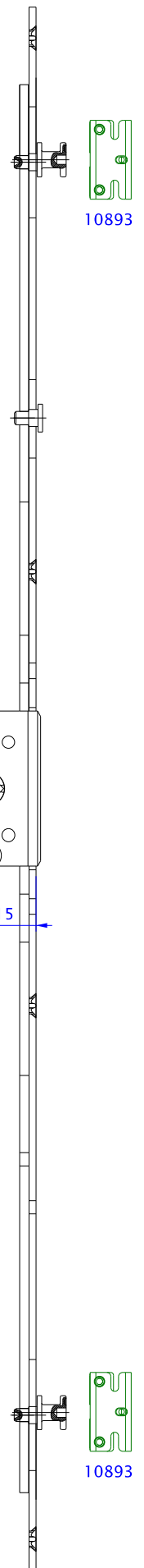
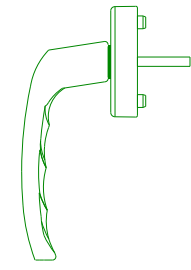

Turn Opening Esp.for Security

Product Number	Sash Dimension	Pin Number
10930	360 – 600	2
10931	600 – 800	2
10932	800 – 1000	2
10933	900 – 1100	3
10934	1000 – 1200	3
10935	1200 – 1400	3
10936	1400 – 1600	4
10937	1600 – 1800	4
10938	1800 – 2000	4
10939	2000 – 2200	4

10816
10825

10816
10825

10903

10816
10825

10816
10825

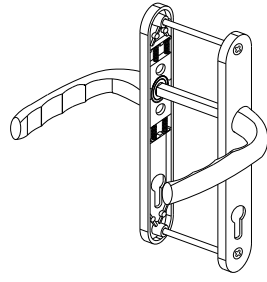

11580

10993 / 180 cm
10994 / 200 cm

85

35

10820

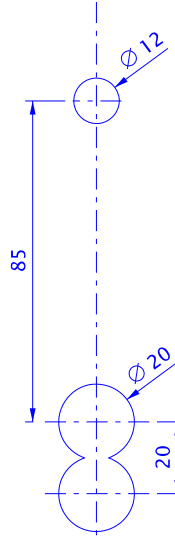

55

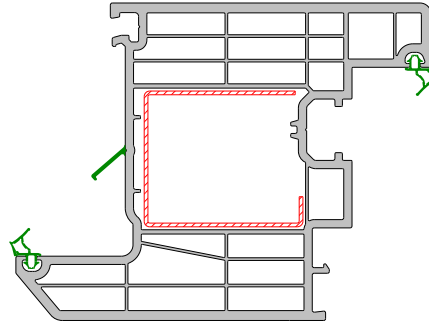

10212

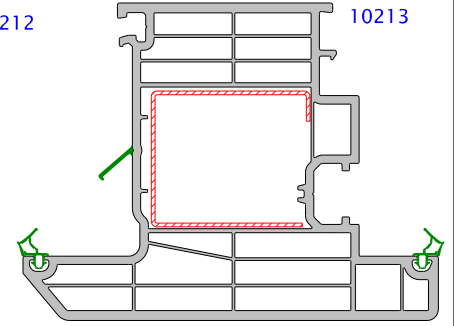

10213

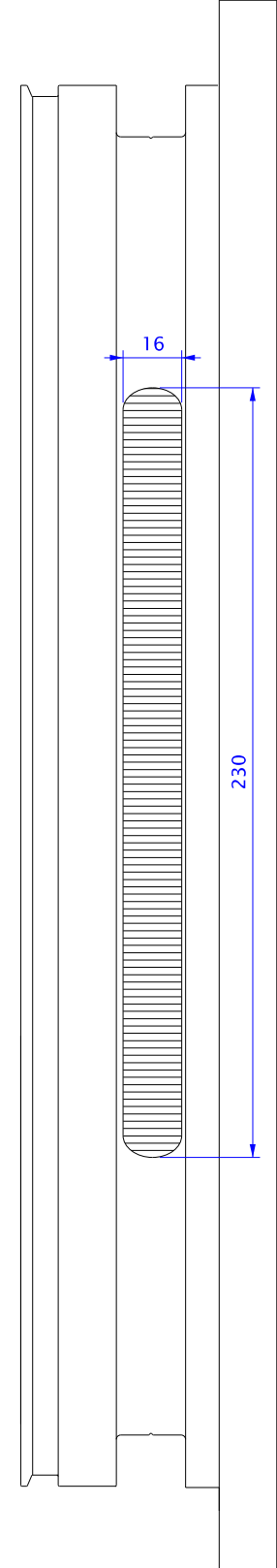

16

230

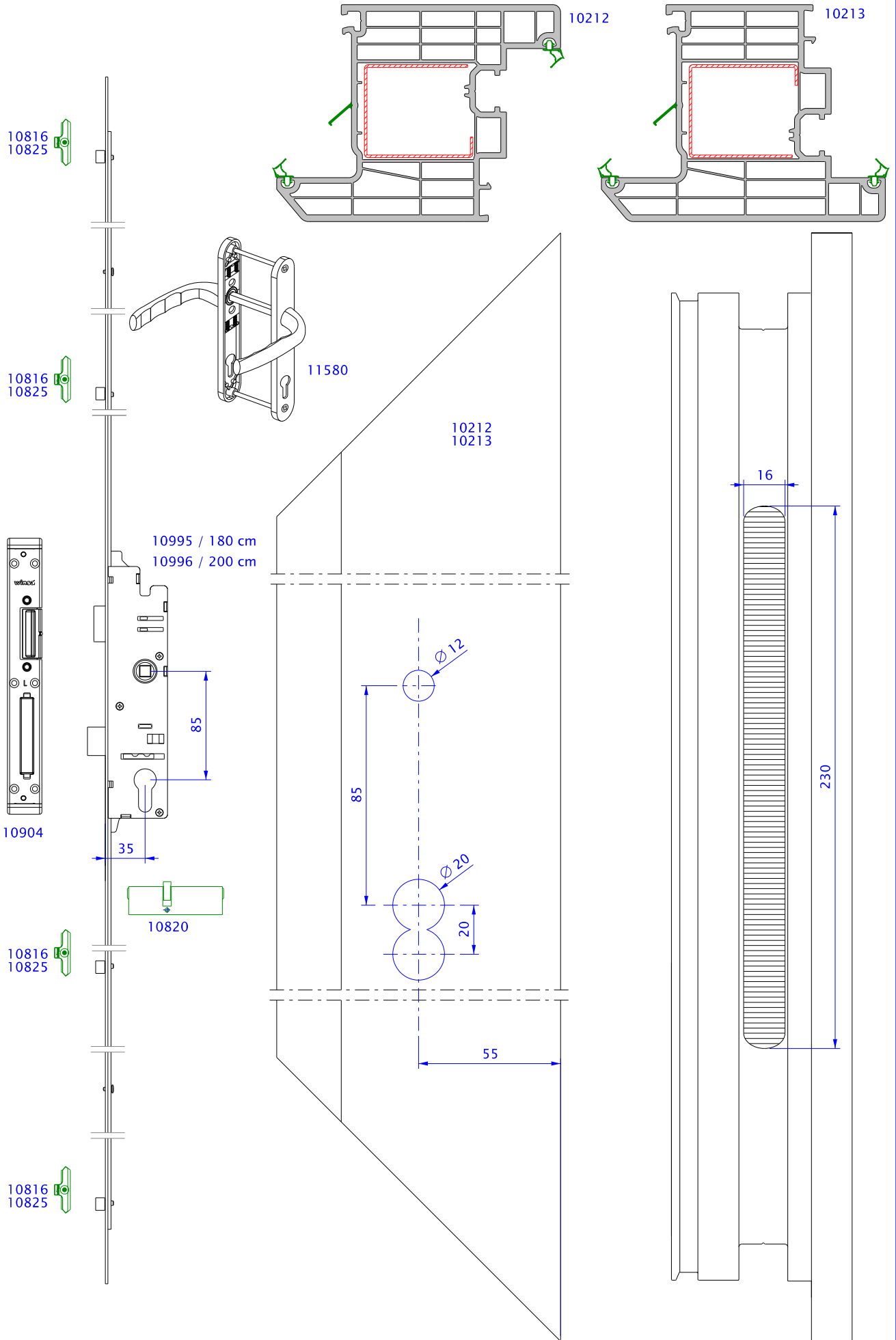

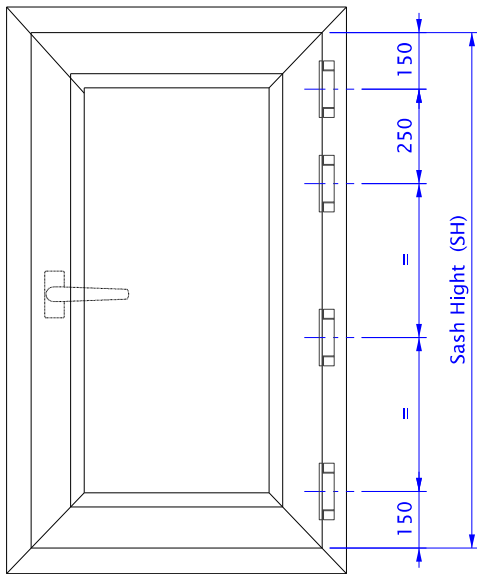

HINGE NUMBER	
SH < 1100 mm	
1101 < SH < 1400 mm	
SH > 1400 mm	

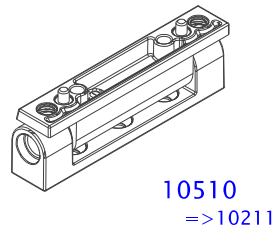
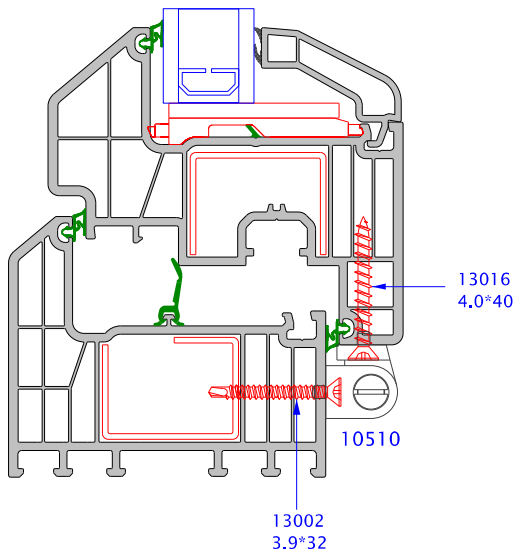

**13894
Revotech Hinge Template**

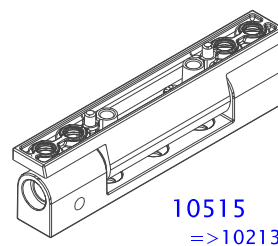
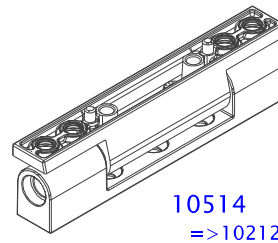
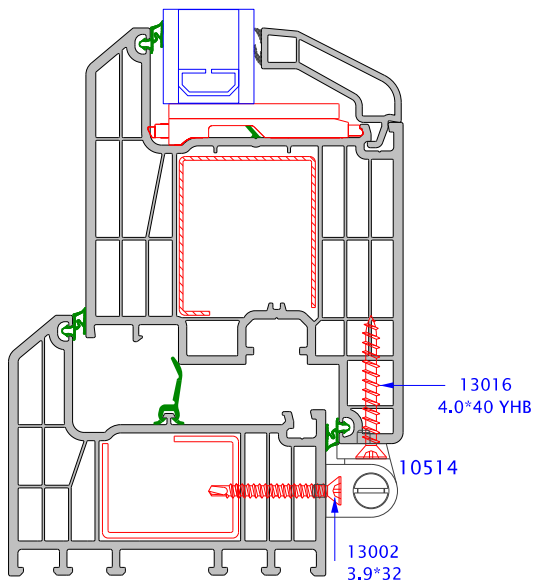
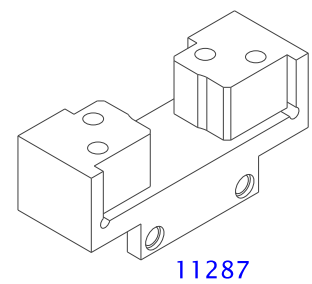

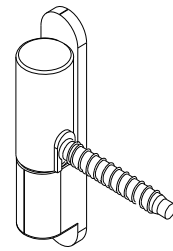
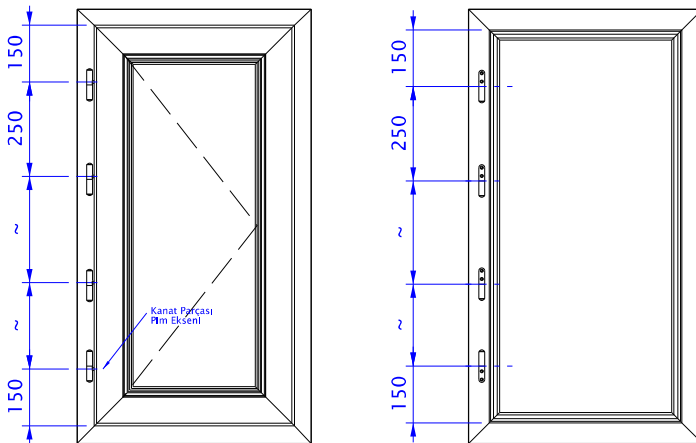

HINGE NUMBER	
SH < 1100 mm	
1101 < SH < 1400 mm	
SH > 1400 mm	

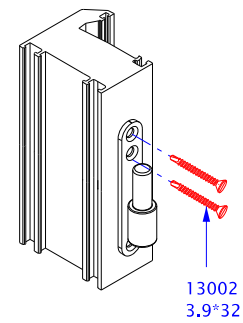

* All hinge holes can be drilled with assembly gage after putting the sash on the frame

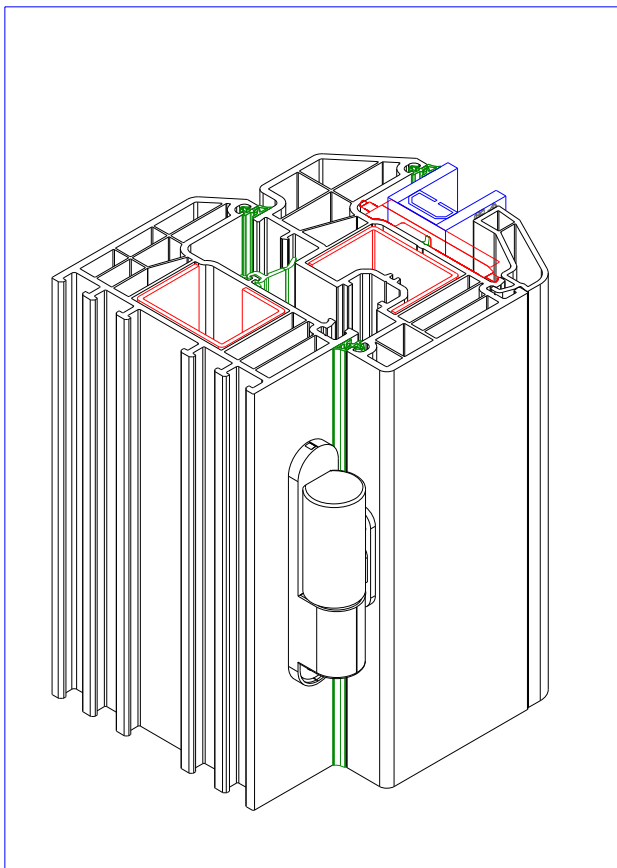

10512
cover



10511
sash
part

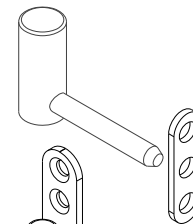

10511
frame
part

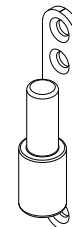

10512
cover



**13895
Hinge Template**

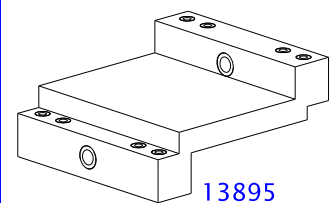

13895

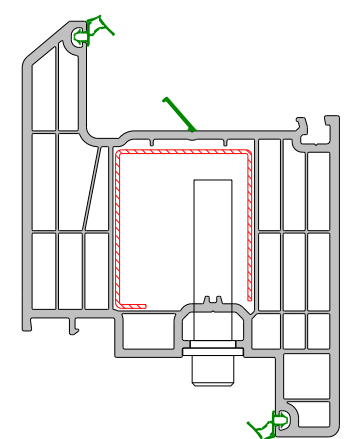
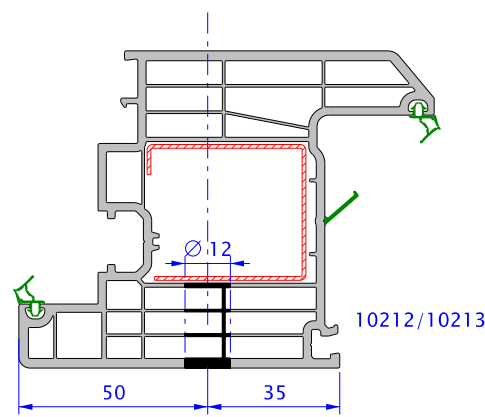
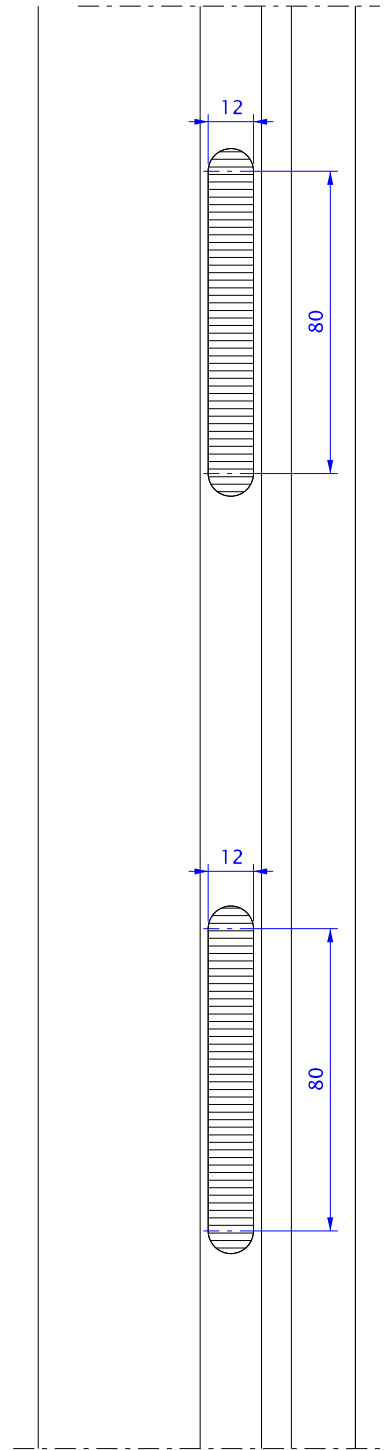
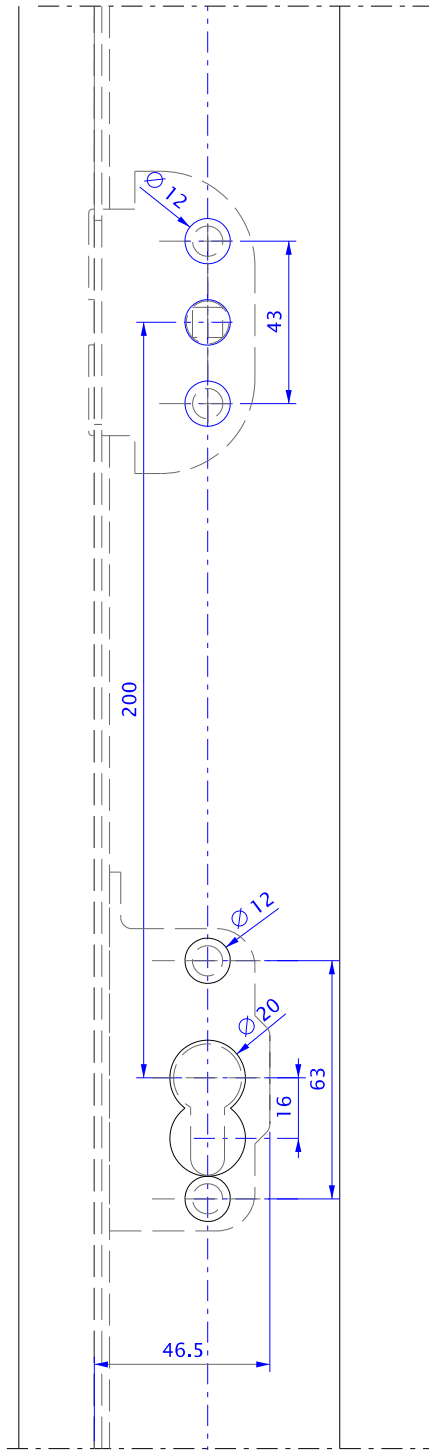
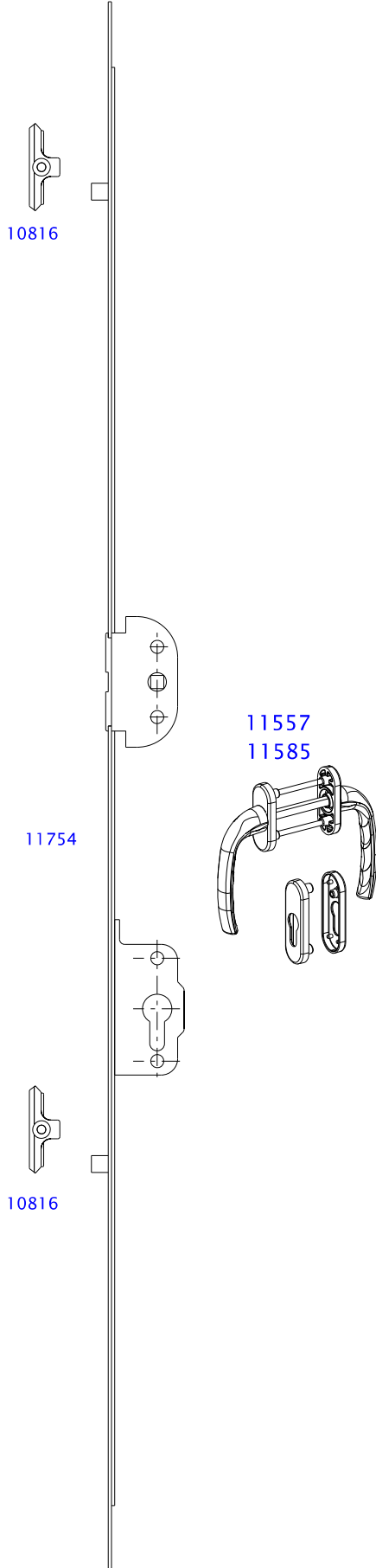

* Handle Axe Length (HAL) : 1073 mm
* If the height of hardware installation slot is between 1700-1800 mm HAL must be in the middle of the sash

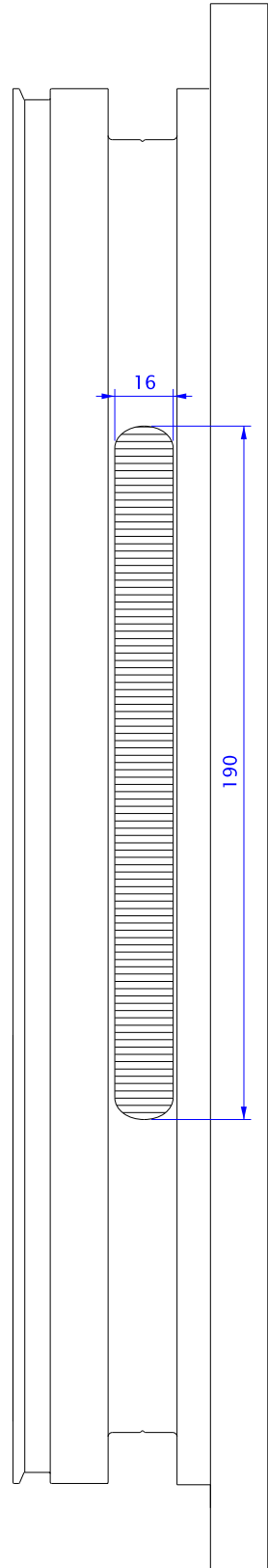
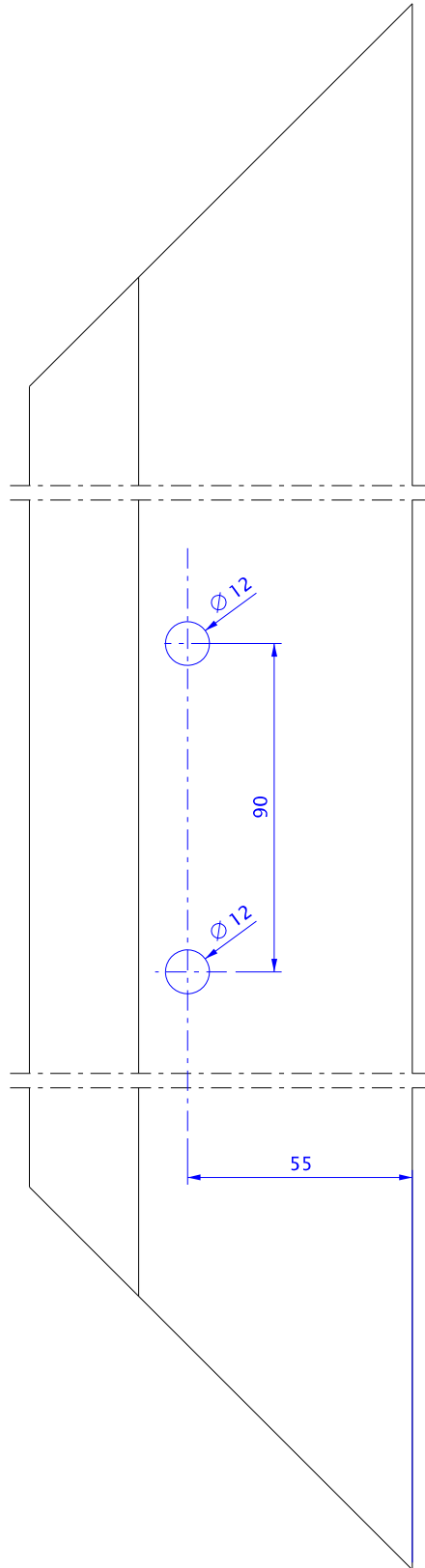
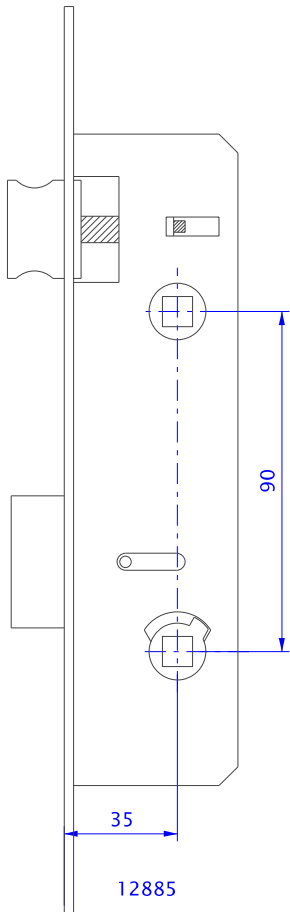
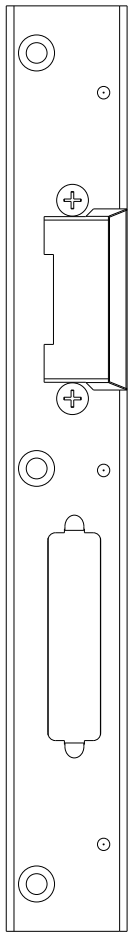
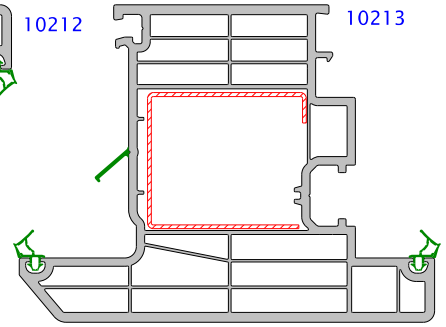
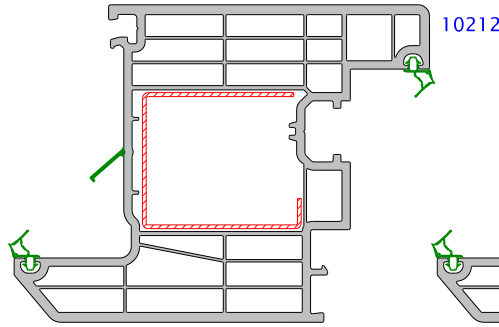
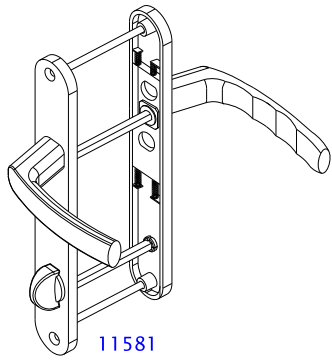

To achieve best welding results, please observe the following :

1. The temperature of profile must be $> 15^{\circ} \text{C}$. (Store at room temperature of min. 15°C)
2. The cutting angle variation must not exceed 0.5°
3. The welding surface must be free of dirty, grease hand sweat, material chips, moisture and protective foils.
4. The welding parameter must be adjusted according to the following criteria.



4.1. Welding plate

Welding Plate Temperature $240^{\circ}\text{--}250^{\circ}\text{C}$,  verification with measuring device on welding plate

4.2 Welding times

- Heating time - a minimum of 15 seconds
- Change-over time as short as possible, maximum of 2 seconds
- Cooling time - a minimum of 30 seconds
- No accelerated cooling (by the use of compressed air)

4.3 Welding pressure:

- Clamping pressure 6 bar 
- Adjusting pressure 2.5-3 bar 
- Welding pressure 6 bar 

5. The welding support blocks must be used,

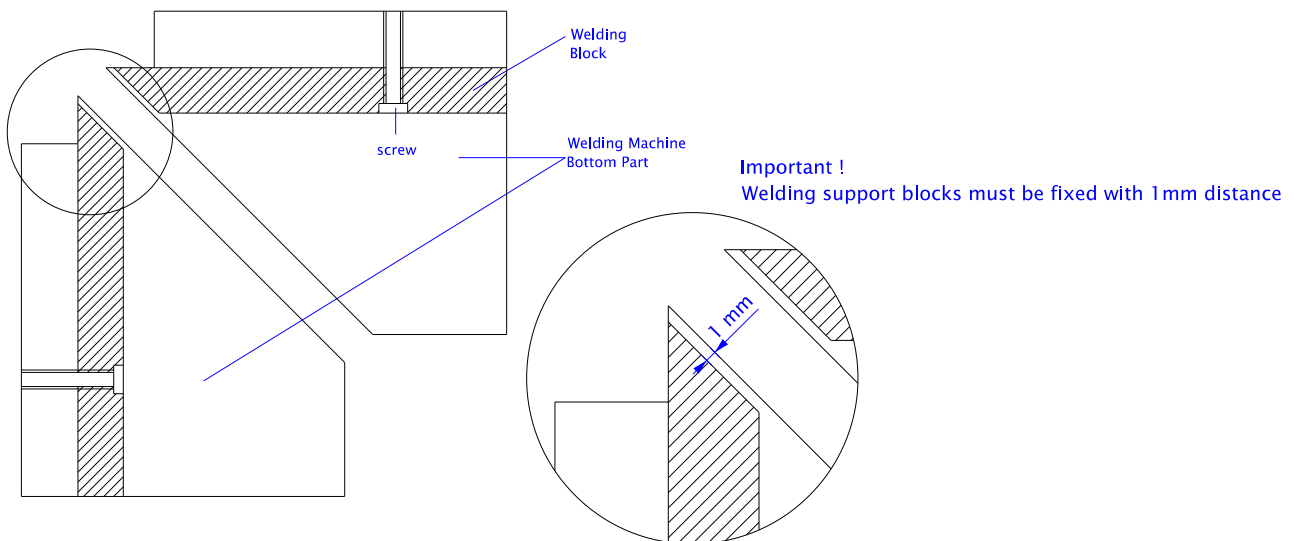

6. Top and bottom pieces of welding support blocks must be parallel to each other
7. Welding thickness must be 3 mm

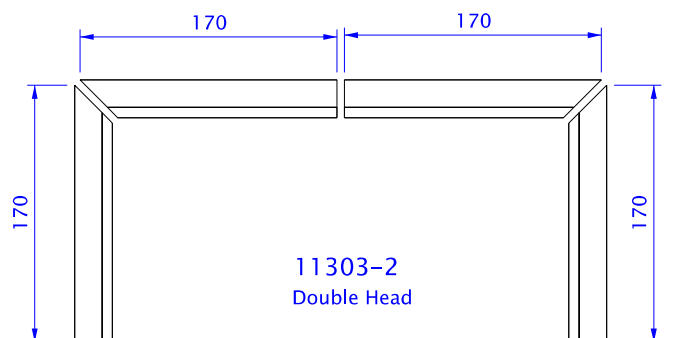
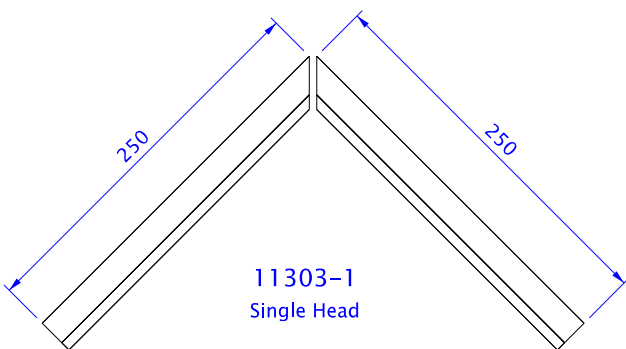
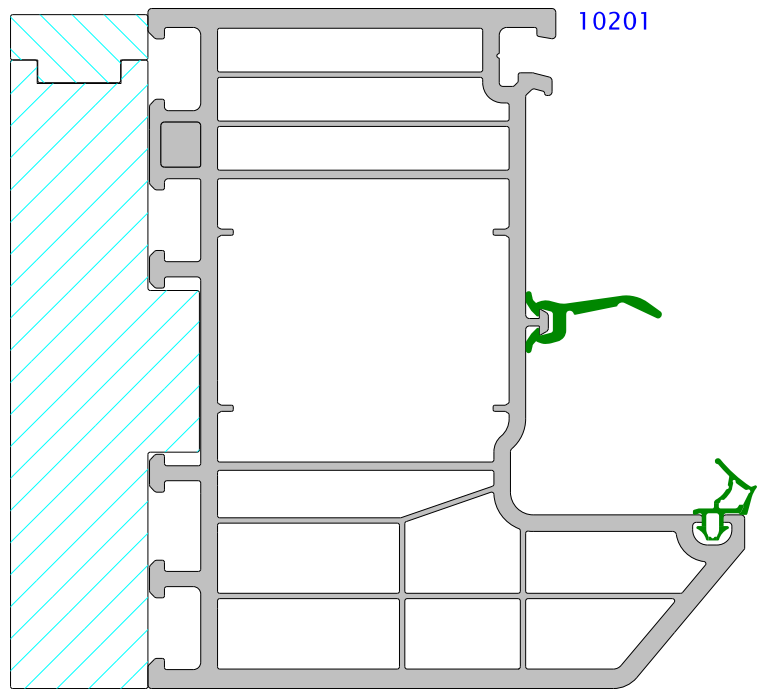
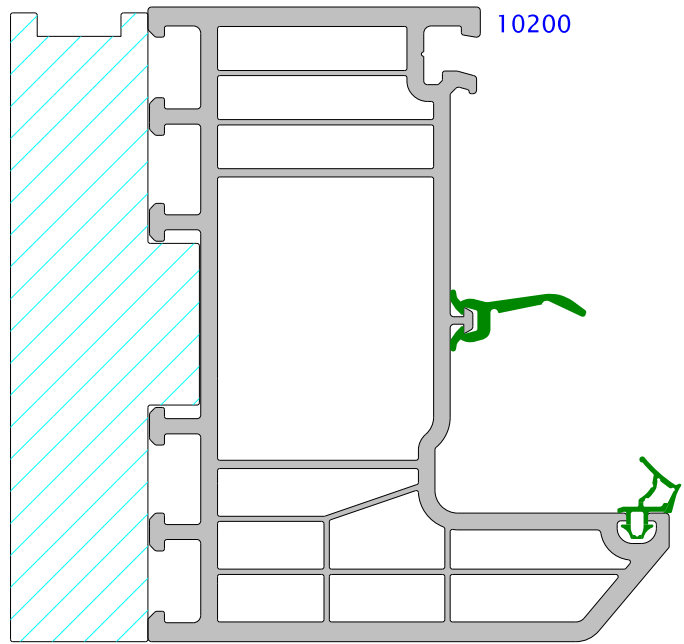
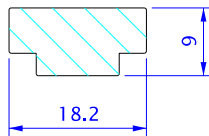
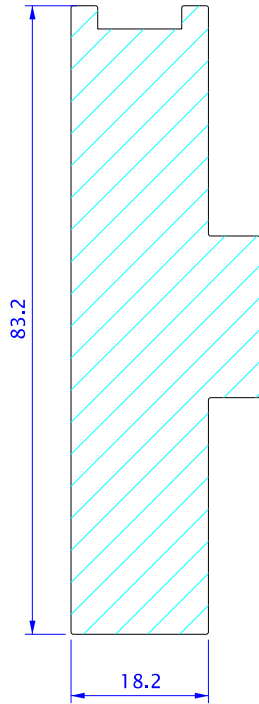

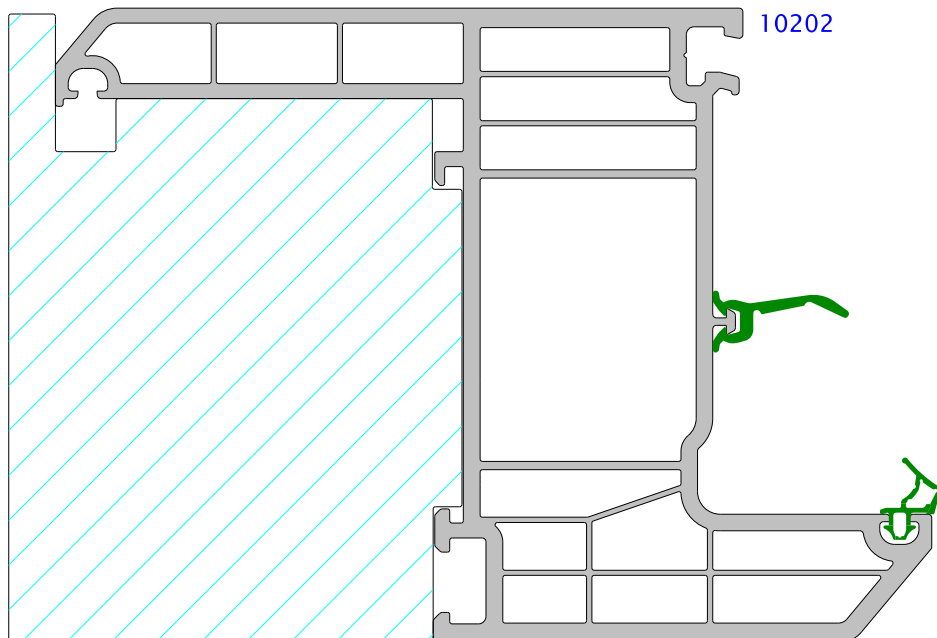
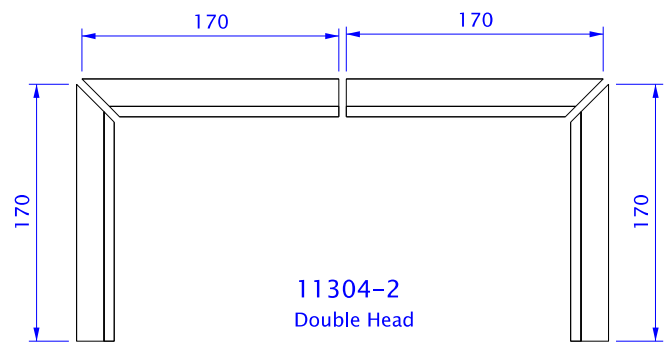
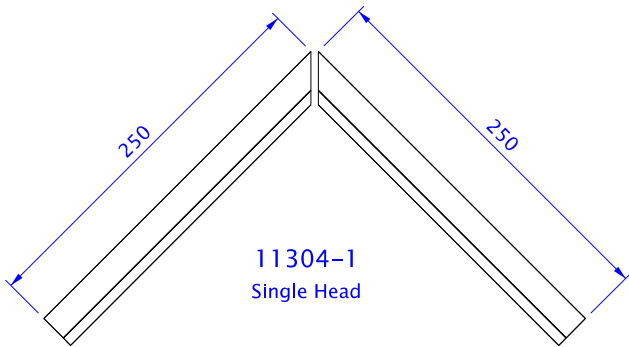
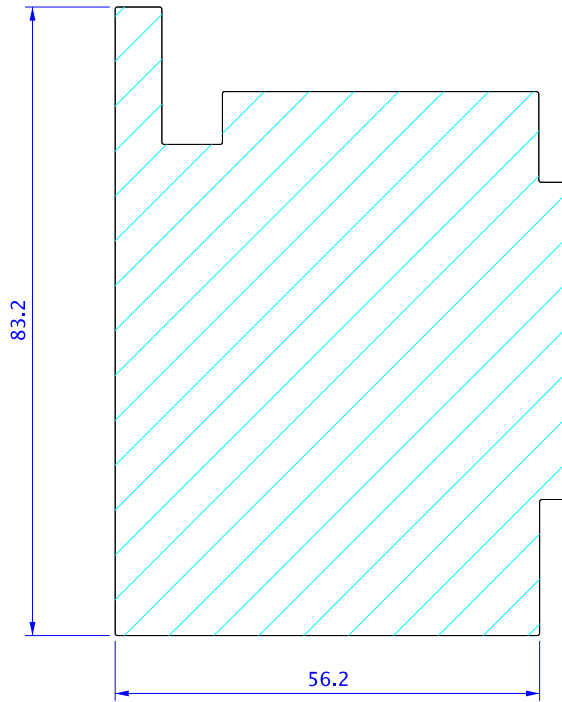

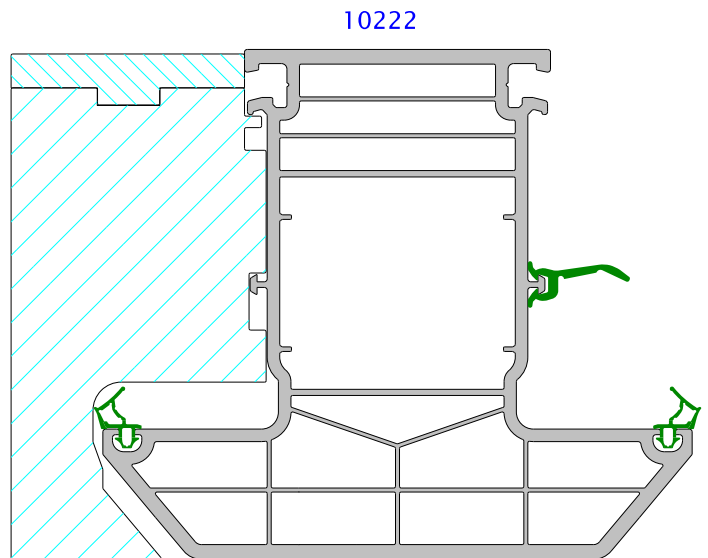
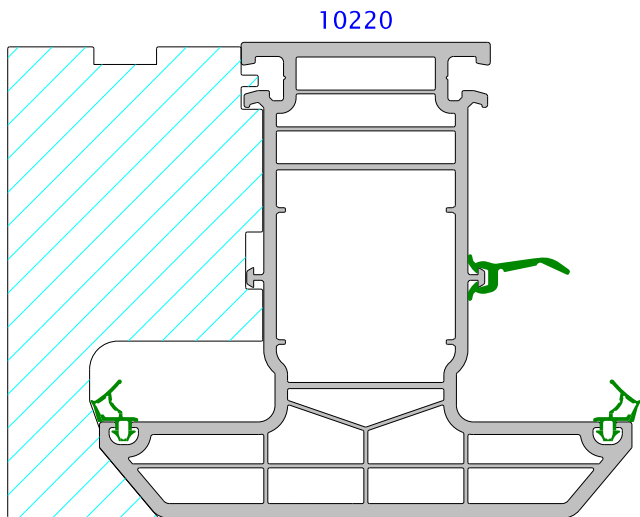
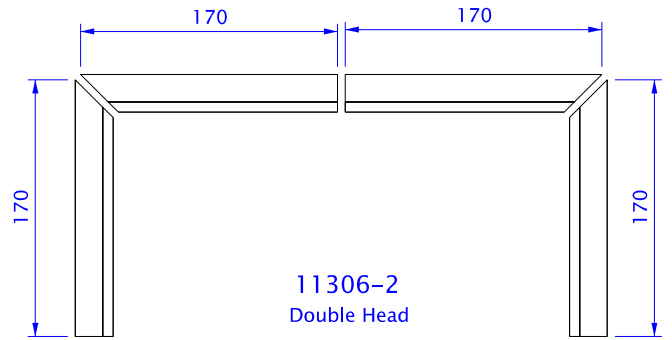
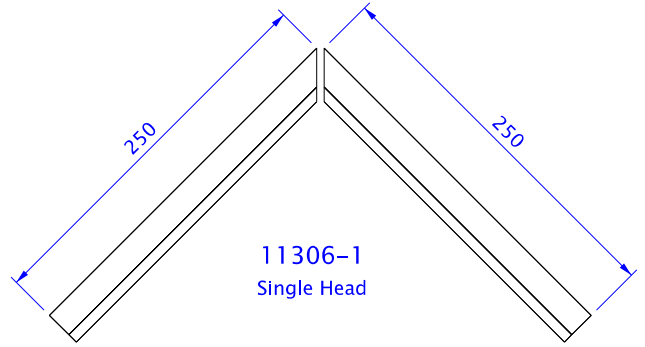
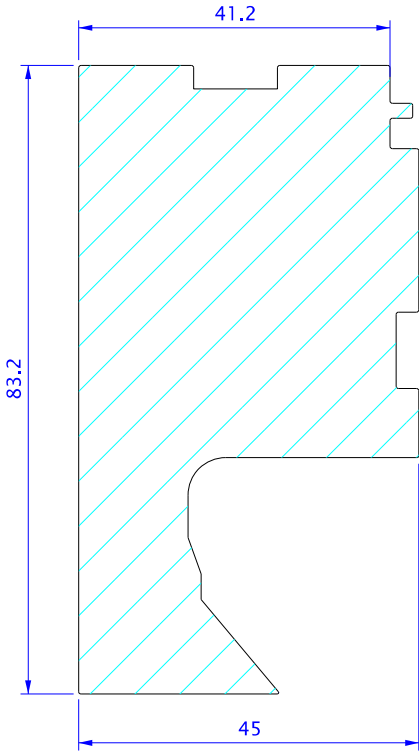
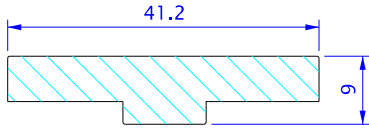

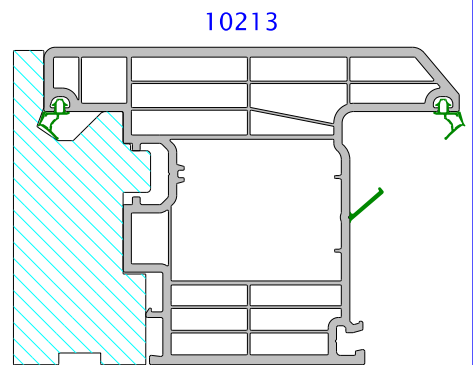
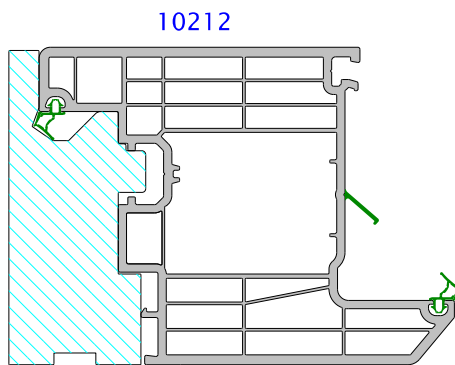
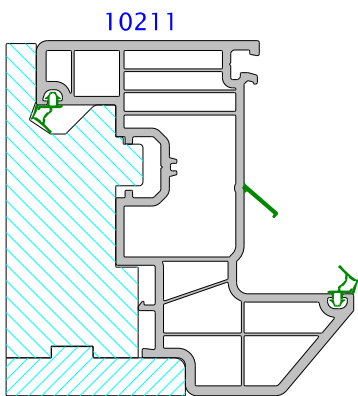
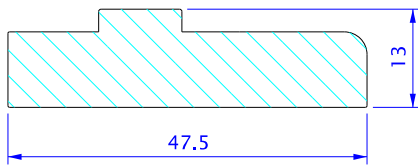
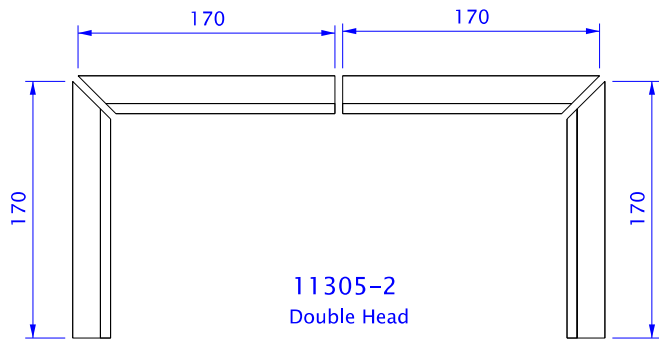
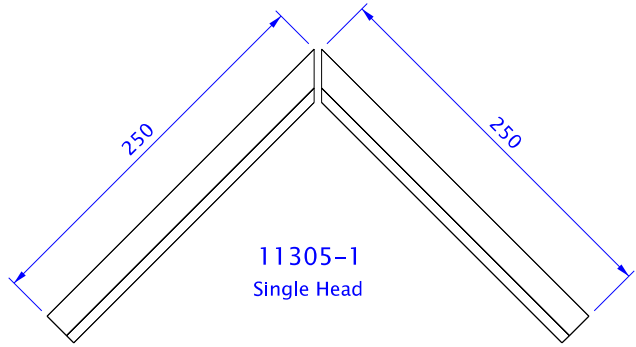
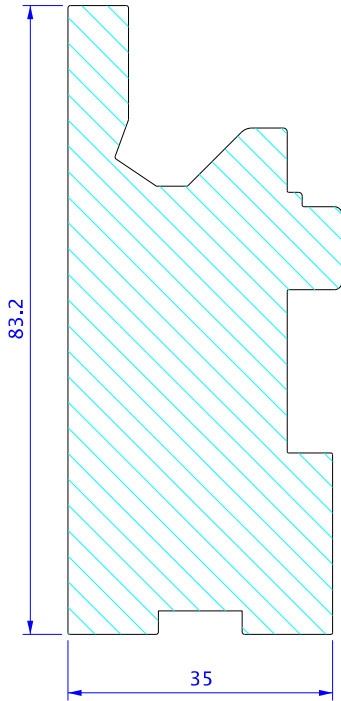

11312 – Revotech 84 Frame Corner Cleaning

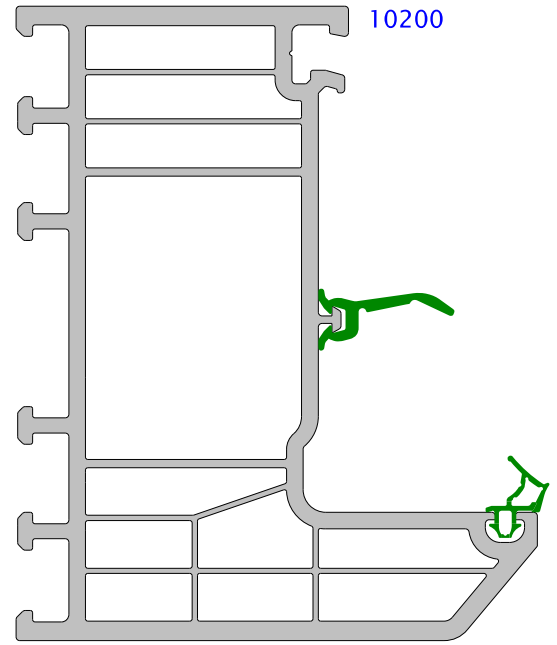
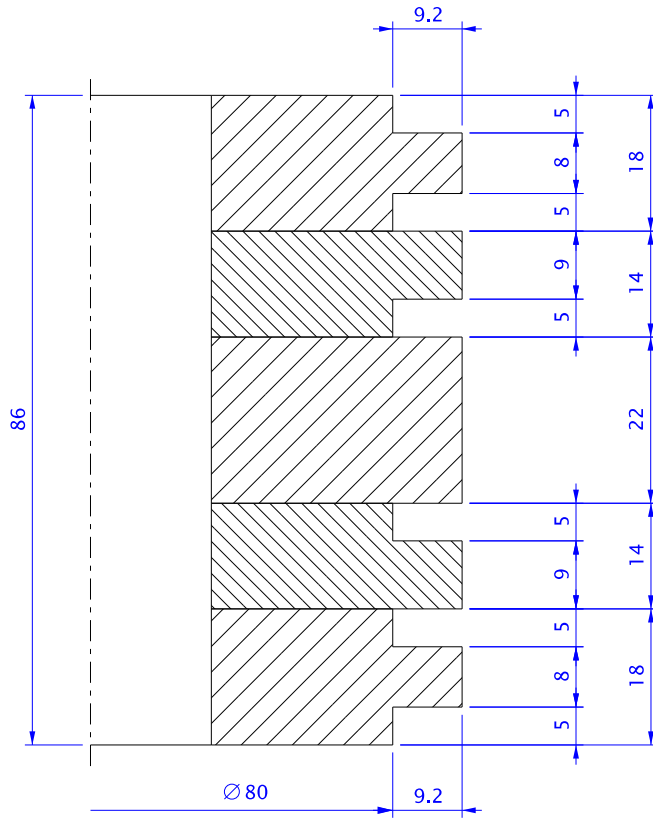

11313 – Revotech 90 Frame Corner Cleaning

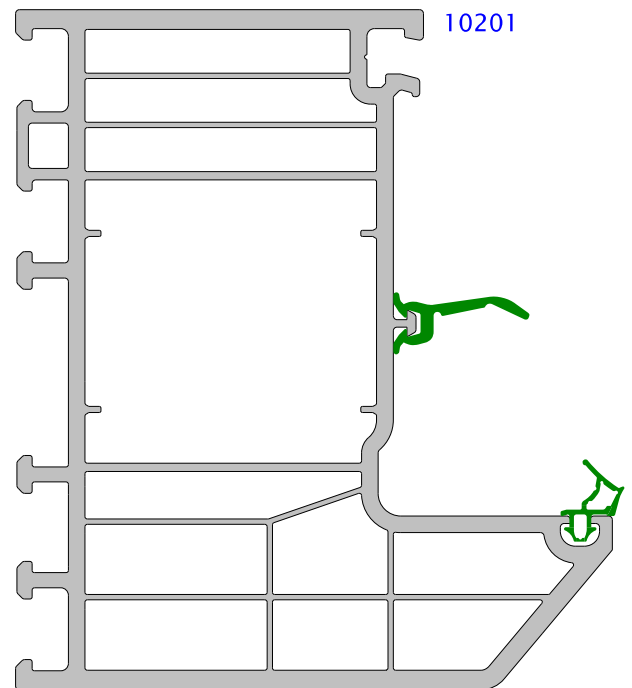
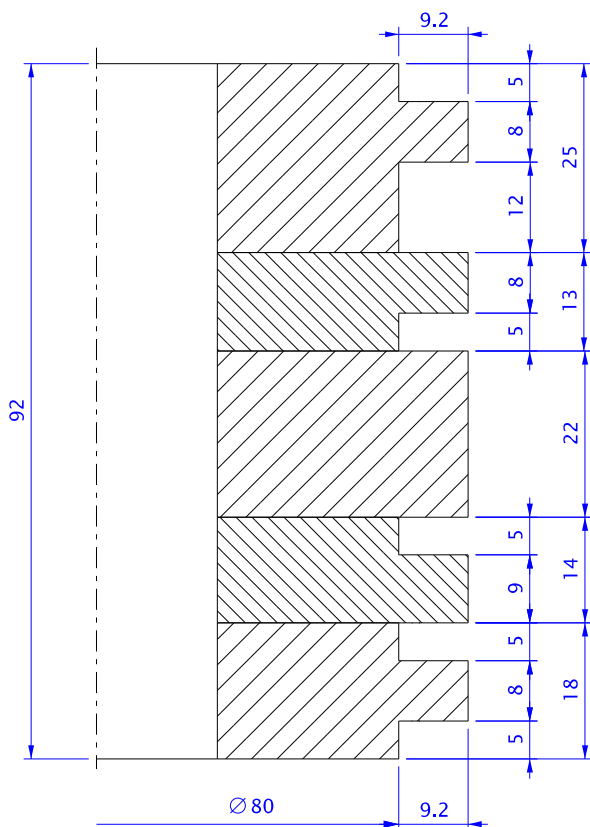

11314 – Revotech Architrave Frame Corner Cleaning

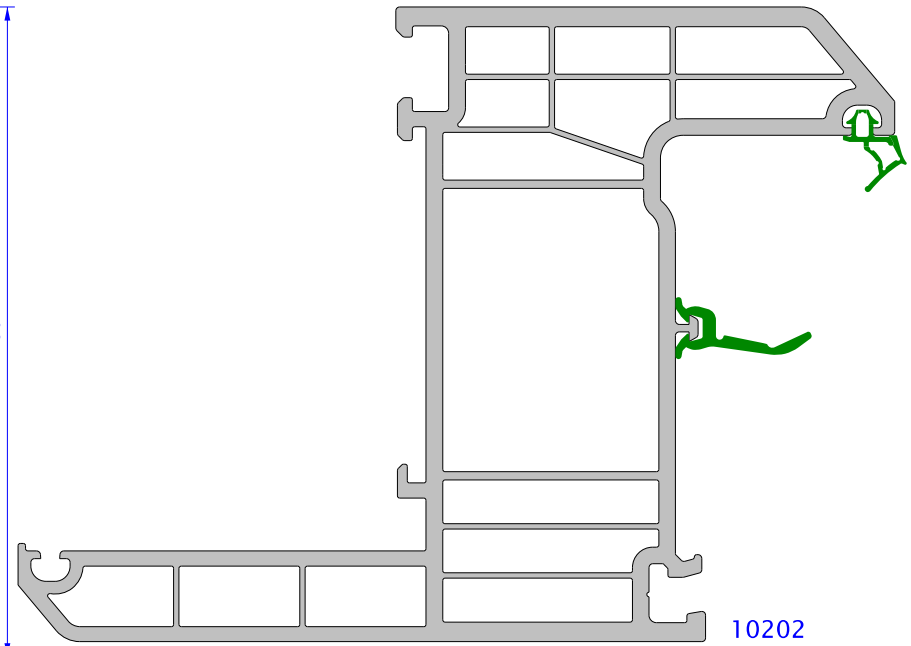
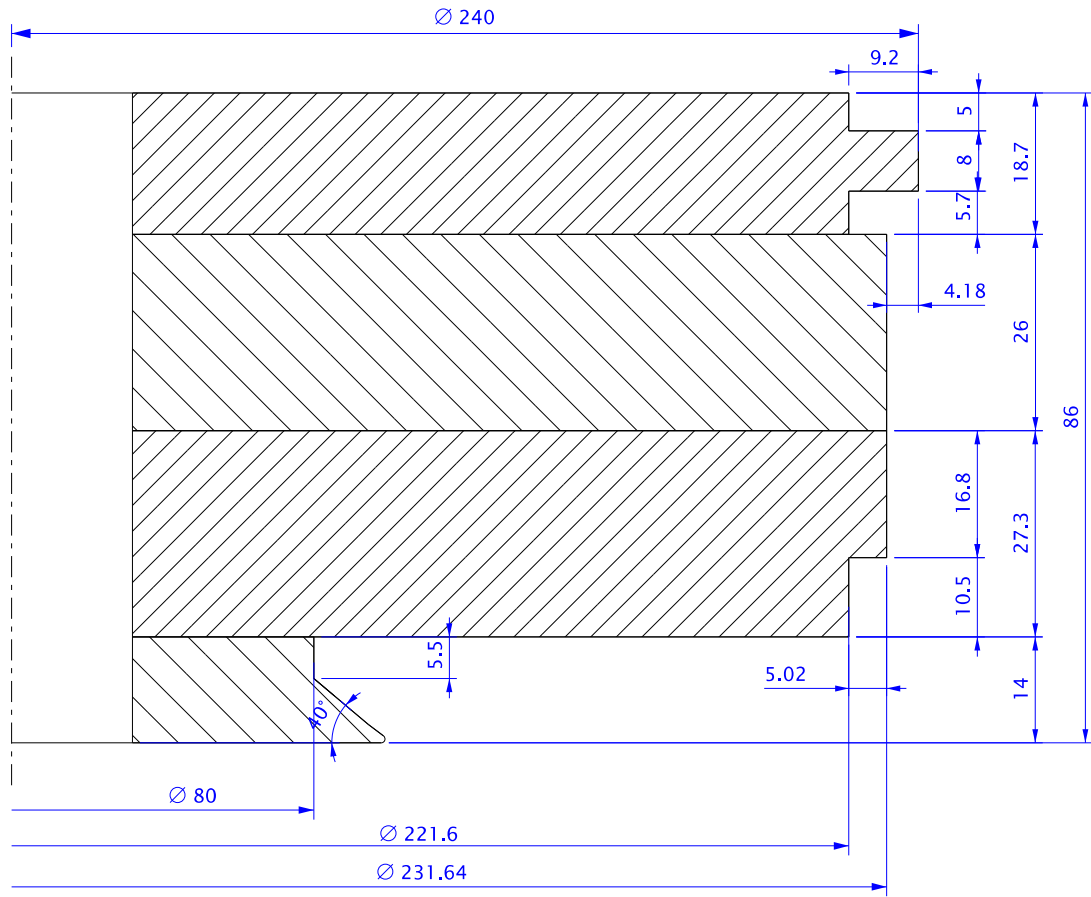

11315 – Revotech Sash Corner Cleaning

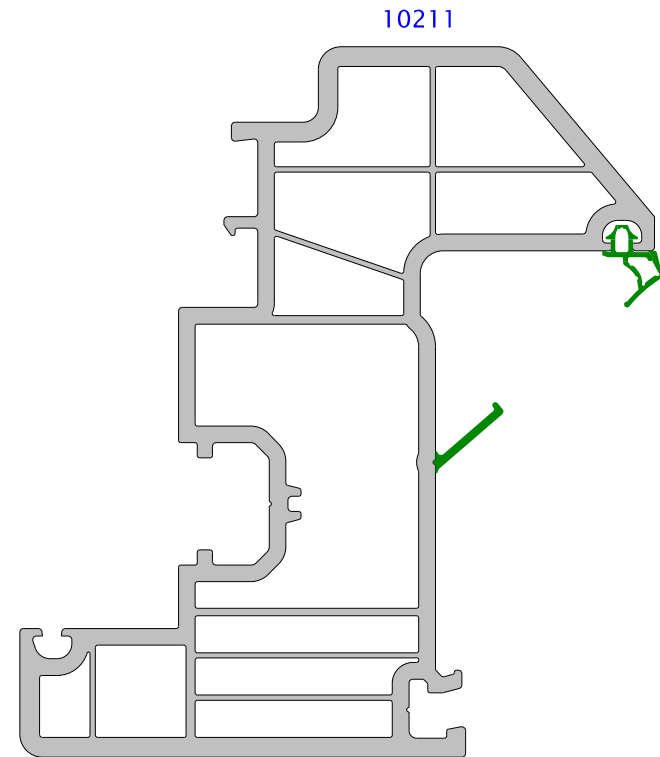
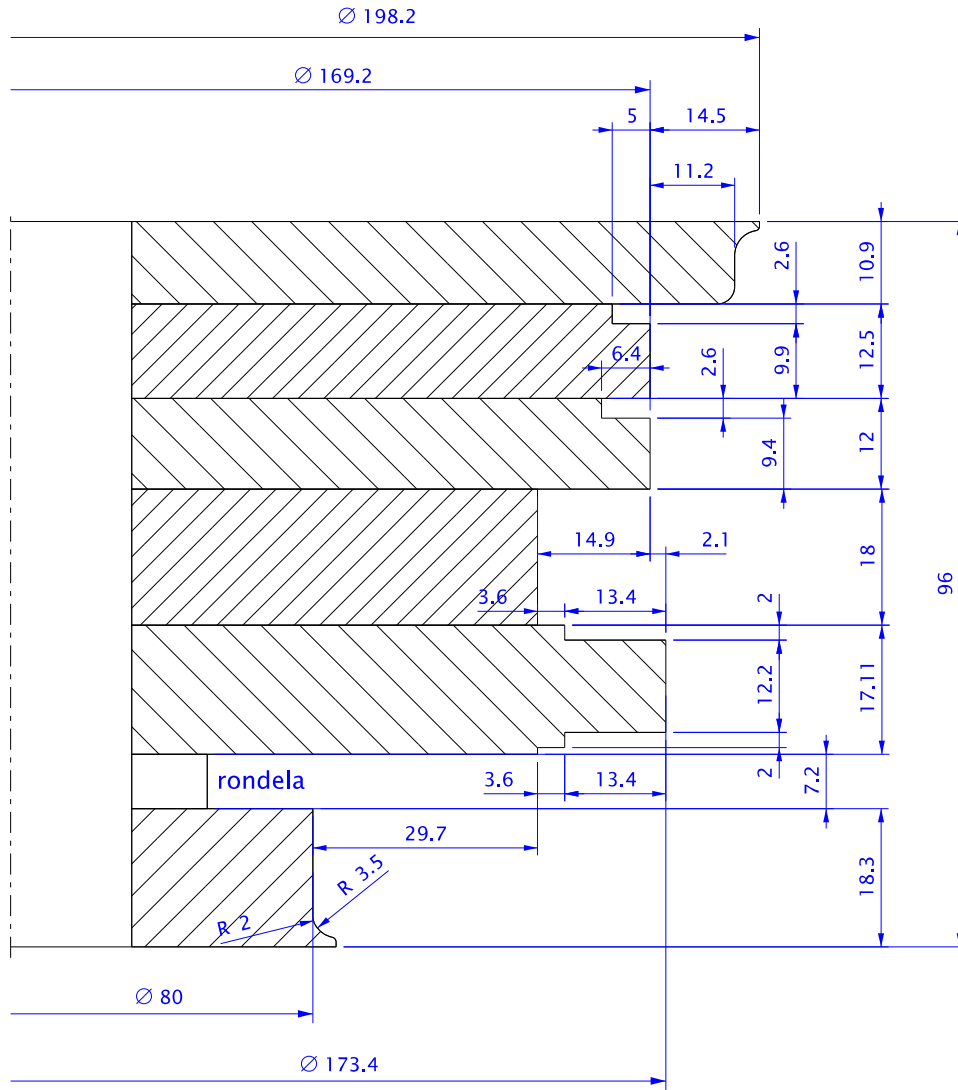

11316 – Revotech Sash Corner Cleaning

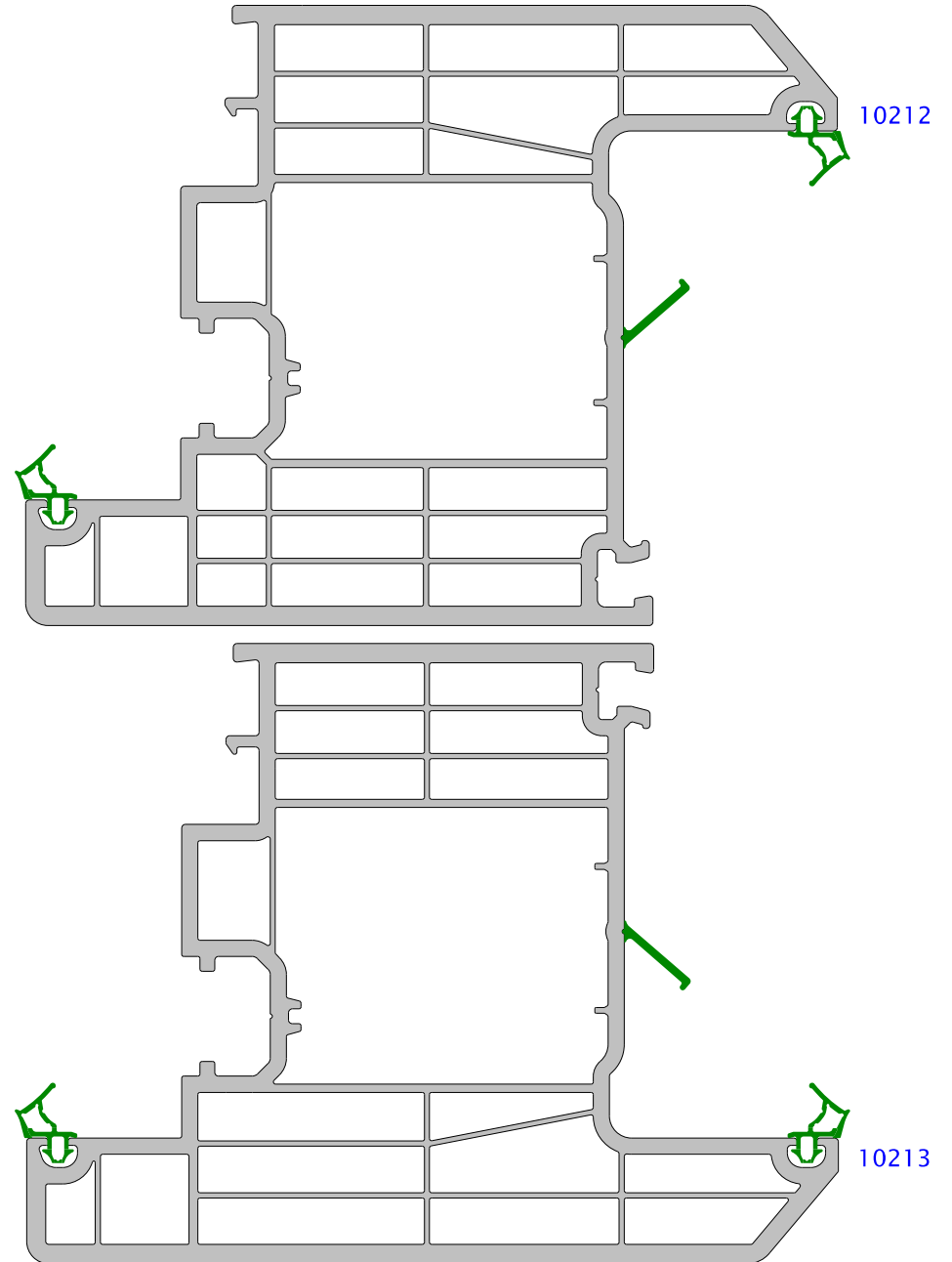
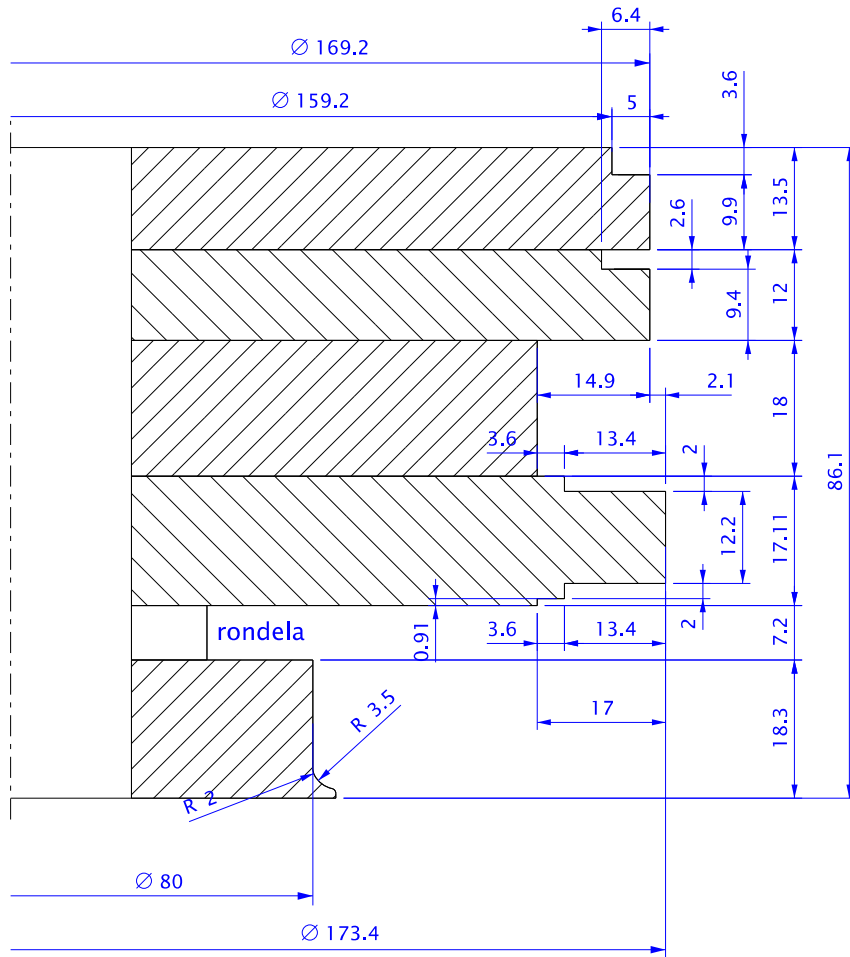

11310 – Revotech 84 End Milling

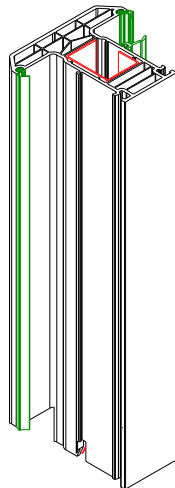
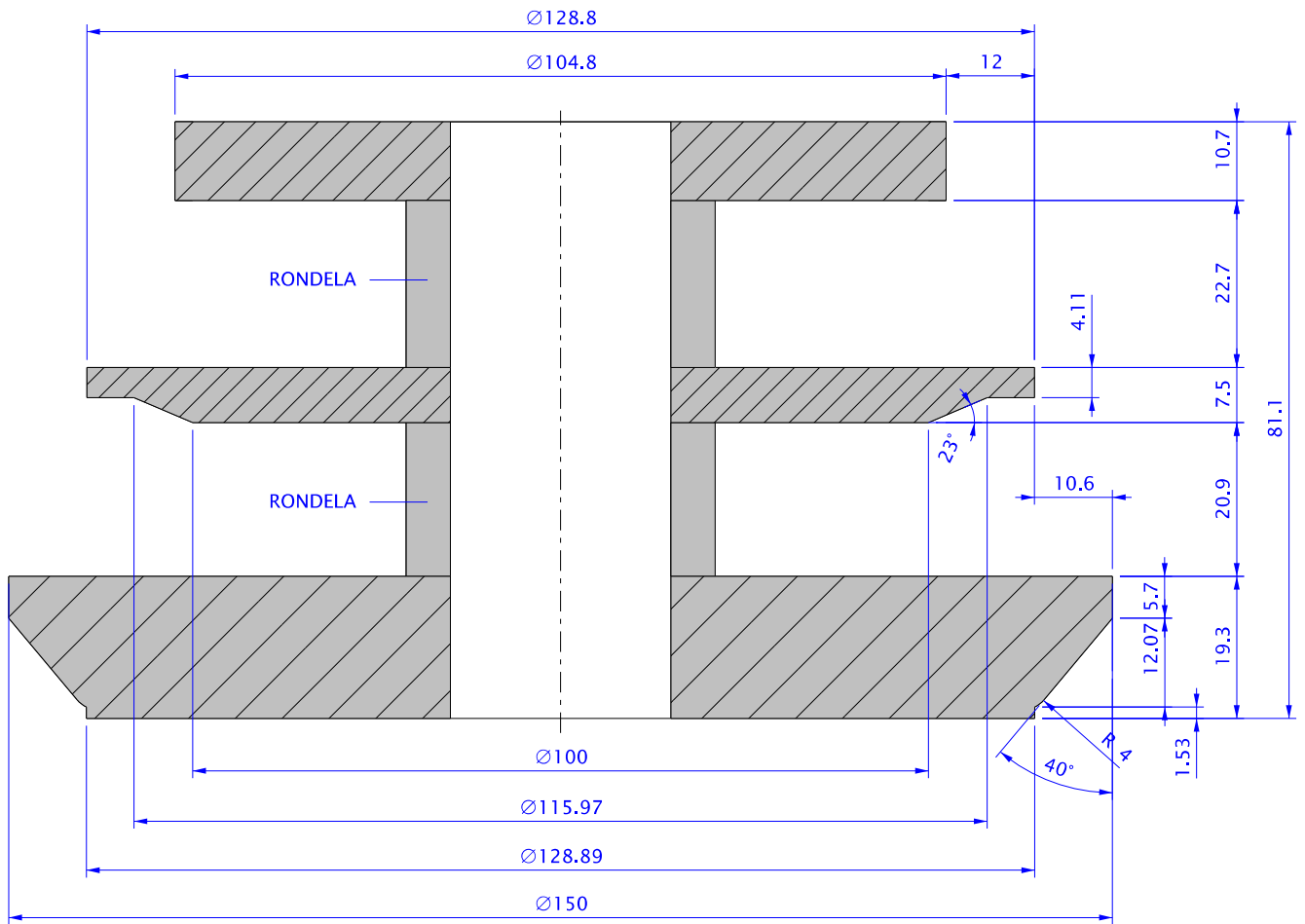

10220

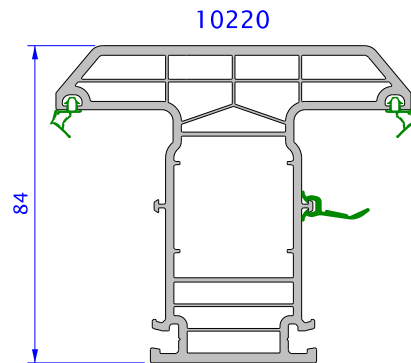

10220

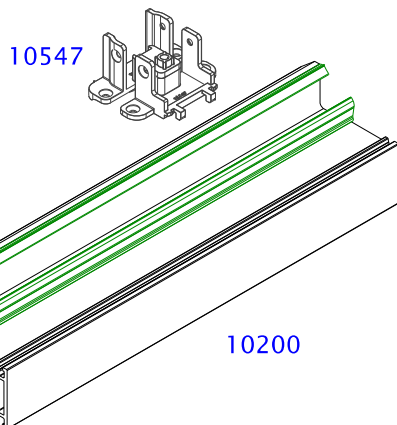

10200

10547

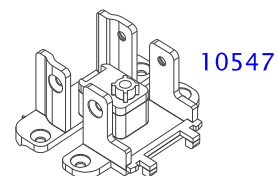

10547

11311 – Revotech 90 End Milling

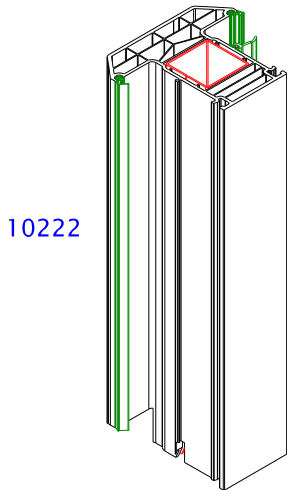
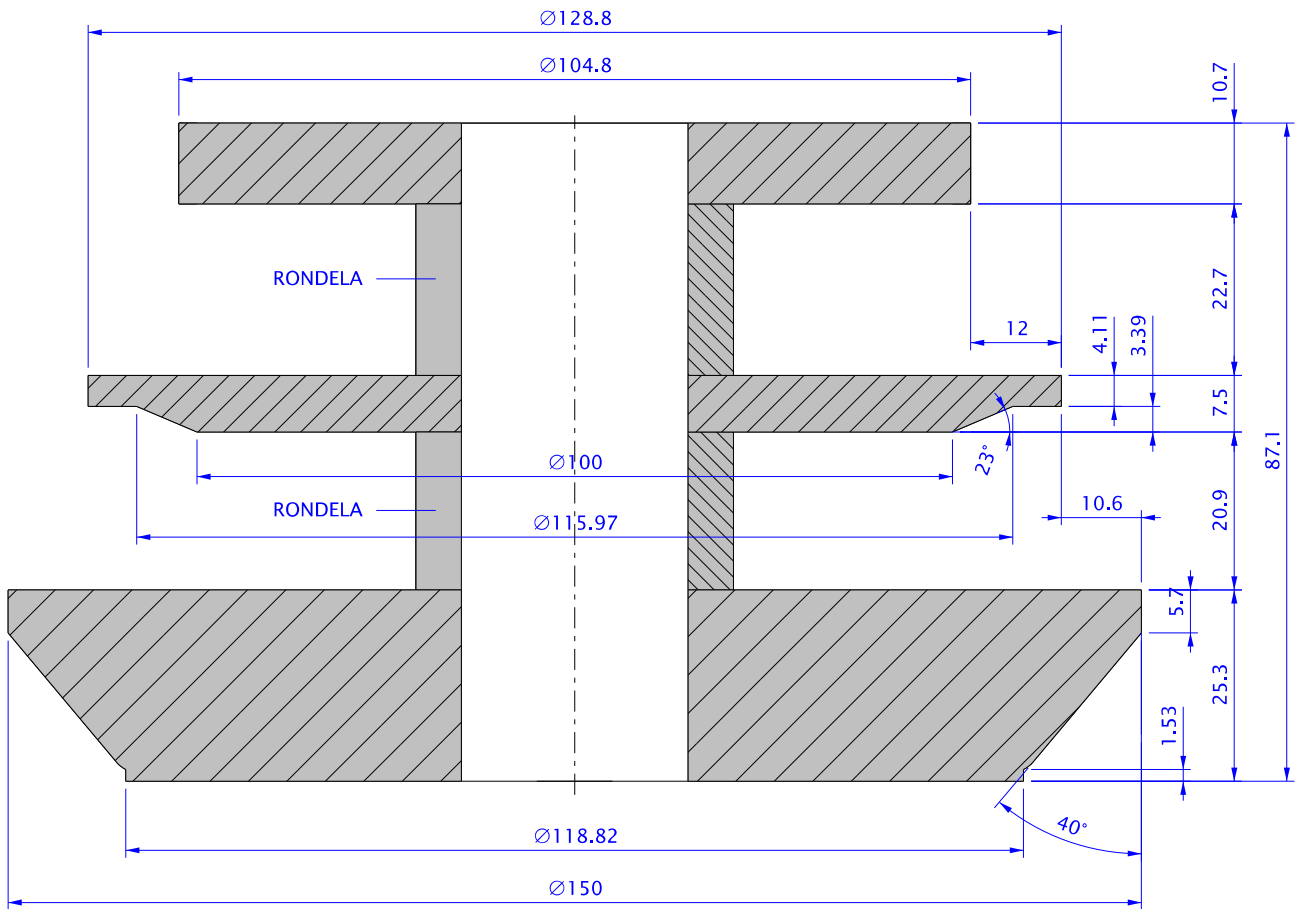

10222

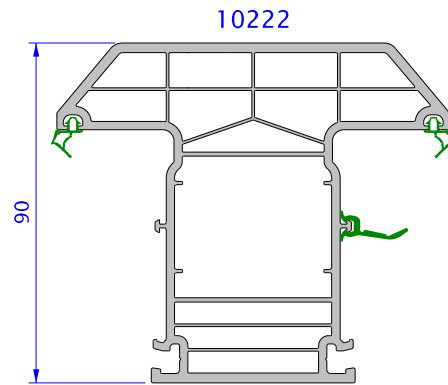

10222

90

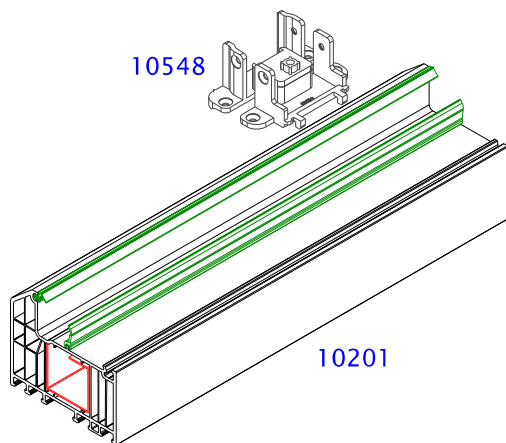

10201

10548

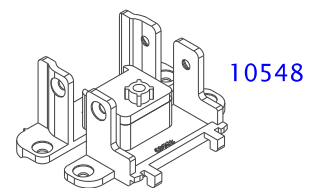

10548

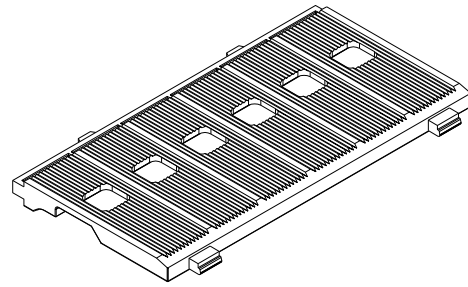

11651

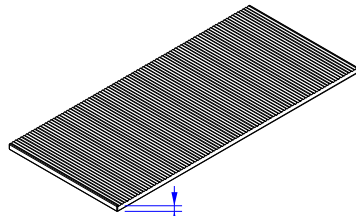
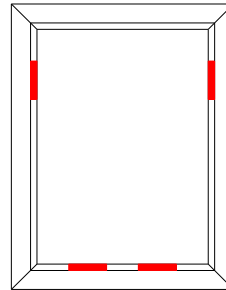

11652

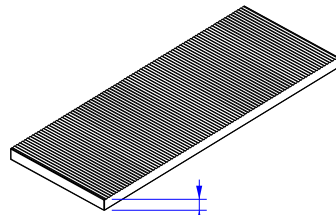
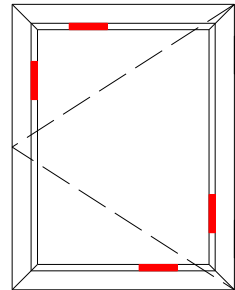

11653

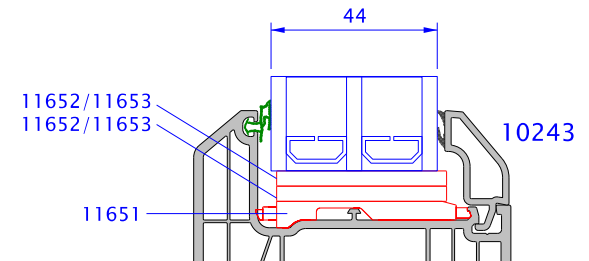
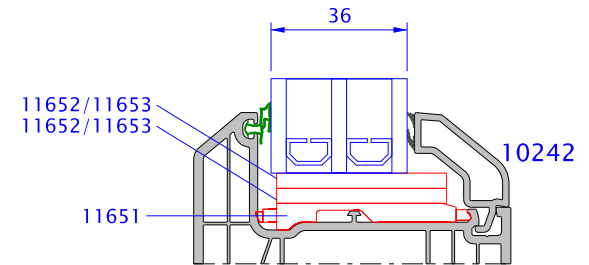
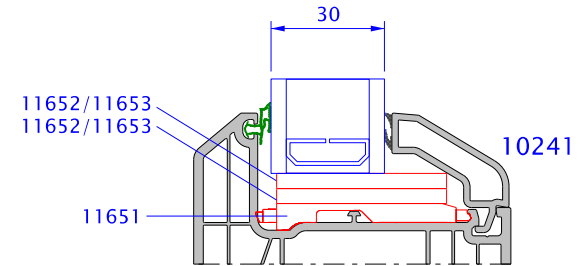
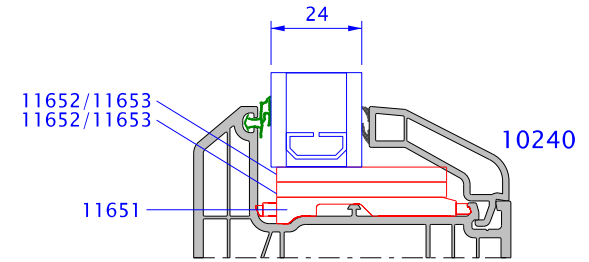
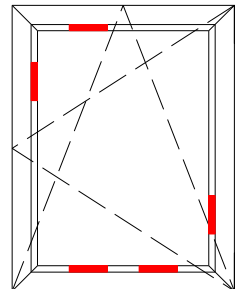

* It is advised to use two pieces 11653

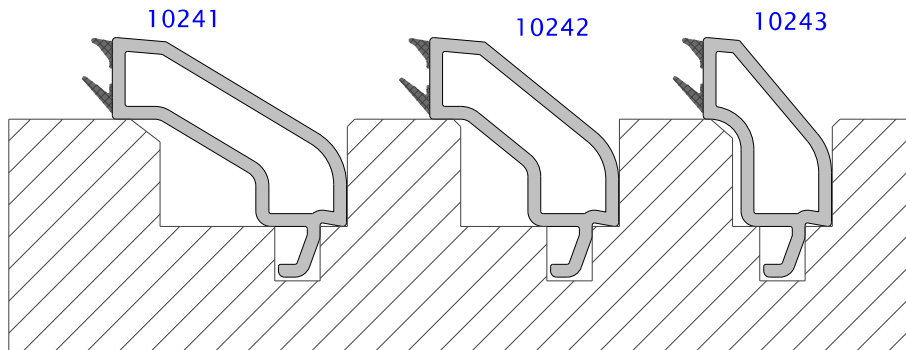
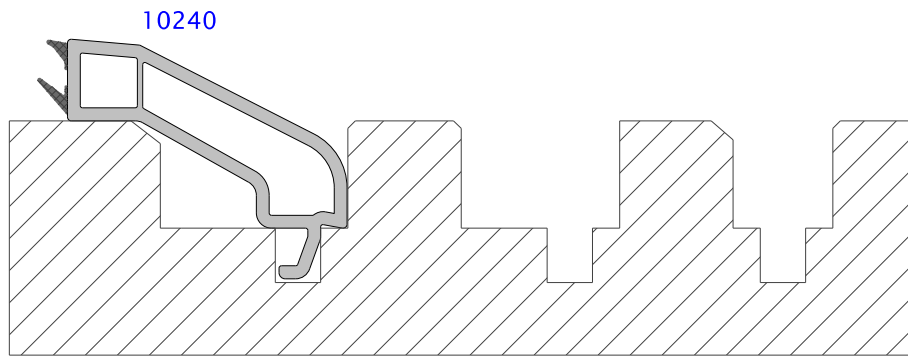
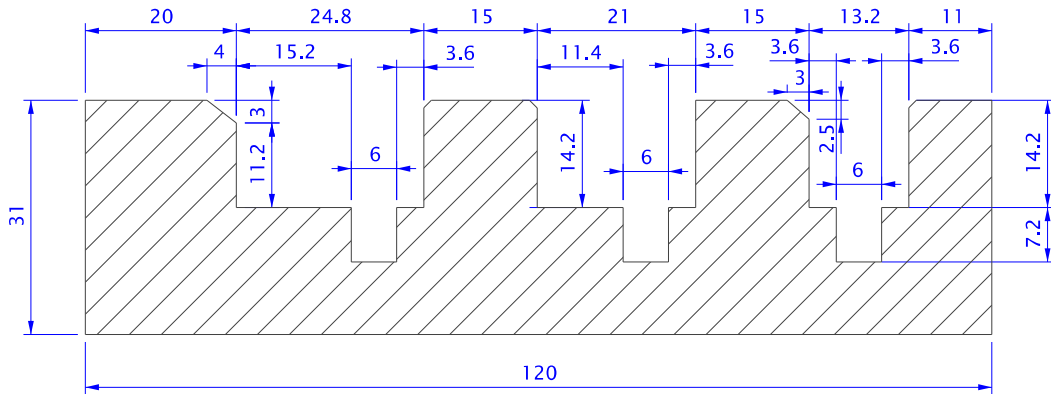

Note : The width of this tool can be change due to the machine types.

winsa[®]

www.winsa.com.tr